

# MITSUBISHI

Integrated FA Software

# CW-Sim (VxWorks Simulator for CW Workbench)

## Operating Manual



Powered by **WIND RIVER** CW-Sim was jointly developed by Mitsubishi and Wind River Systems, Inc.

Integrated FA Software

- SW1DNC-CWSIM-E
- SW1DNC-CWSIMSA-E



# ● SAFETY PRECAUTIONS ●

(Read these precautions before using this product.)

Before using this product, please read this manual and the relevant manuals carefully and pay full attention to safety to handle the product correctly.

In this manual, the safety precautions are classified into two levels: "⚠ WARNING" and "⚠ CAUTION".



Indicates that incorrect handling may cause hazardous conditions, resulting in death or severe injury.



Indicates that incorrect handling may cause hazardous conditions, resulting in minor or moderate injury or property damage.

Under some circumstances, failure to observe the precautions given under "⚠ CAUTION" may lead to serious consequences.

Make sure that the end users read this manual and then keep the manual in a safe place for future reference.

## [Design Precautions]

### ⚠ WARNING

To control external devices, configure an interlock circuit in the user program to ensure that the entire system will always operate safely.

Especially, in the case of a control to a remote external device, immediate action cannot be taken for a problem due to a communication failure.

To prevent this, configure an interlock circuit in the user program, and determine corrective actions to be taken between external devices in case of a communication failure.

## [Startup and Maintenance Precautions]

### ⚠ CAUTION

To control external devices, configure an interlock circuit in the user program to ensure that the entire system will always operate safely.

Especially, in the case of a control to a remote external device, immediate action cannot be taken for a problem due to a communication failure.

To prevent this, configure an interlock circuit in the user program, and determine corrective actions to be taken between external devices in case of a communication failure.

### ⚠ WARNING

When connecting any external device during operations of CW-Sim and CW-Sim Standalone, ensure the safety. Improper operation may damage machines or cause accidents.

# ● CONDITIONS OF USE FOR THE PRODUCT ●

- (1) Mitsubishi CW-Sim/CW-Sim Standalone ("the PRODUCT") shall be used in conditions;
  - i) where any problem, fault or failure occurring in the PRODUCT, if any, shall not lead to any major or serious accident; and
  - ii) where the backup and fail-safe function are systematically or automatically provided outside of the PRODUCT for the case of any problem, fault or failure occurring in the PRODUCT.
  
- (2) The PRODUCT has been designed and manufactured for the purpose of being used in general industries.

MITSUBISHI SHALL HAVE NO RESPONSIBILITY OR LIABILITY (INCLUDING, BUT NOT LIMITED TO ANY AND ALL RESPONSIBILITY OR LIABILITY BASED ON CONTRACT, WARRANTY, TORT, PRODUCT LIABILITY) FOR ANY INJURY OR DEATH TO PERSONS OR LOSS OR DAMAGE TO PROPERTY CAUSED BY the PRODUCT THAT ARE OPERATED OR USED IN APPLICATION NOT INTENDED OR EXCLUDED BY INSTRUCTIONS, PRECAUTIONS, OR WARNING CONTAINED IN MITSUBISHI'S USER, INSTRUCTION AND/OR SAFETY MANUALS, TECHNICAL BULLETINS AND GUIDELINES FOR the PRODUCT.

("Prohibited Application")

Prohibited Applications include, but not limited to, the use of the PRODUCT in;

- Nuclear Power Plants and any other power plants operated by Power companies, and/or any other cases in which the public could be affected if any problem or fault occurs in the PRODUCT.
- Railway companies or Public service purposes, and/or any other cases in which establishment of a special quality assurance system is required by the Purchaser or End User.
- Aircraft or Aerospace, Medical applications, Train equipment, transport equipment such as Elevator and Escalator, Incineration and Fuel devices, Vehicles, Manned transportation, Equipment for Recreation and Amusement, and Safety devices, handling of Nuclear or Hazardous Materials or Chemicals, Mining and Drilling, and/or other applications where there is a significant risk of injury to the public or property.

Notwithstanding the above, restrictions Mitsubishi may in its sole discretion, authorize use of the PRODUCT in one or more of the Prohibited Applications, provided that the usage of the PRODUCT is limited only for the specific applications agreed to by Mitsubishi and provided further that no special quality assurance or fail-safe, redundant or other safety features which exceed the general specifications of the PRODUCTS are required. For details, please contact the Mitsubishi representative in your region.

# INTRODUCTION

Thank you for purchasing CW-Sim/CW-Sim Standalone.  
This manual explains about the product.

Before using this product, please read this manual and the relevant manuals carefully and develop familiarity with the functions and performance of CW-Sim/CW-Sim Standalone and applicable modules to handle the product correctly.

## RELEVANT MANUALS

The manuals related to the product are listed below.  
Please place an order as needed.

Manual <Manual No. and model code>	Description
CW Workbench Operating Manual <SH-080982ENG, 13JU71>	The manual describes system configuration, specifications, functions, and troubleshooting of CW Workbench.
C Controller Module User's Manual (Q24DHCCPU-V) <SH-081130ENG, 13JZ75>	The manual describes system configuration, specifications, functions, handling methods, wiring, troubleshooting, and programming and function of the Q24DHCCPU-V C Controller module.
C Controller Module User's Manual (Hardware Design, Function Explanation) <SH-080766ENG, 13JY80>	The manual describes system configuration, specifications, functions, handling methods, wiring, and troubleshooting of the Q12DCCPU-V C Controller module.
Wind River VxWorks Simulator 6.0 USER'S GUIDE (Japanese) Wind River VxWorks Simulator 6.1 USER'S GUIDE (English)*1 Wind River VxWorks Simulator 6.8 USER'S GUIDE (English)*2	The manuals describe specifications, usage methods, troubleshooting, and relevant documents of Wind River VxWorks Simulator that is the base for this product. Refer to the manuals for the same functions as Wind River VxWorks Simulator. A PDF file of the manuals is stored on the CD-ROM disc of the product.

\*1 : The material related to VxWorks 6.4 (target operating system with Q12DCCPU-V)

\*2 : The material related to VxWorks 6.8 (target operating system with Q24DHCCPU-V)

# CONTENTS

SAFETY PRECAUTIONS .....	1
CONDITIONS OF USE FOR THE PRODUCT .....	2
INTRODUCTION .....	3
RELEVANT MANUALS .....	3
MANUAL PAGE ORGANIZATION .....	7
GENERIC TERMS AND ABBREVIATIONS .....	9
TERMS .....	9
<hr/>	
<b>CHAPTER 1 OVERVIEW</b> .....	<b>10</b>
<hr/>	
1.1 Features .....	10
<hr/>	
<b>CHAPTER 2 SYSTEM CONFIGURATION</b> .....	<b>12</b>
<hr/>	
2.1 Device Configuration .....	12
2.2 Communication Paths Available for CW-Sim/CW-Sim Standalone .....	13
2.3 Relevant Modules .....	13
<hr/>	
<b>CHAPTER 3 OPERATING ENVIRONMENT</b> .....	<b>14</b>
<hr/>	
<b>CHAPTER 4 SPECIFICATIONS</b> .....	<b>15</b>
<hr/>	
4.1 Specifications of CW-Sim and CW-Sim Standalone .....	15
4.2 Differences from C Controller Module .....	15
<hr/>	
<b>CHAPTER 5 PACKING LIST</b> .....	<b>16</b>
<hr/>	
5.1 Packing List .....	16
5.2 Preparation before Using CW-Sim .....	17
5.3 Preparation before Using CW-Sim Standalone .....	18
<hr/>	
<b>CHAPTER 6 PROCEDURE OVERVIEW</b> .....	<b>19</b>
<hr/>	
6.1 From Installation of CW-Sim to Debugging of Programs .....	19
6.2 From Installation of CW-Sim to Execution of Programs .....	21
<hr/>	
<b>CHAPTER 7 PERMANENT LICENSE</b> .....	<b>22</b>
<hr/>	
7.1 Obtaining Permanent License .....	22
7.2 Applying Permanent License .....	23
7.3 Deleting Permanent License .....	24
7.4 Re-applying Permanent License .....	25
<hr/>	
<b>CHAPTER 8 INSTALLATION AND UNINSTALLATION</b> .....	<b>27</b>
<hr/>	
8.1 Installation of CW-Sim .....	27
8.1.1 Preparation before installation .....	27
8.1.2 How to install CW-Sim .....	29
8.1.3 Operations after installation .....	34
8.1.4 After installation .....	34

8.2	Uninstallation of CW-Sim .....	35
8.3	Installation of CW-Sim Standalone .....	35
8.4	Uninstallation of CW-Sim Standalone .....	36
<hr/> <b>CHAPTER 9 APPLYING PATCH</b>		<b>37</b>
9.1	How to Obtain Patch .....	38
9.2	How to Apply Patch .....	38
<hr/> <b>CHAPTER 10 VxWORKS NETWORK DAEMON SETTINGS</b>		<b>40</b>
10.1	Windows® 7 .....	40
10.2	Windows Vista® .....	46
10.3	Windows® XP .....	50
<hr/> <b>CHAPTER 11 CREATING AND BUILDING PROJECT</b>		<b>54</b>
11.1	Creating Project .....	54
11.1.1	Creating new project .....	54
11.1.2	Creating project using sample program .....	61
11.2	Building Project .....	64
11.2.1	How to build new project .....	64
11.2.2	Building project using sample program .....	64
<hr/> <b>CHAPTER 12 PROGRAM DEBUGGING WITH CW-SIM</b>		<b>65</b>
12.1	VxWorks Network Daemon Startup .....	65
12.2	Simulator Startup .....	66
12.3	Debugging Program .....	69
<hr/> <b>CHAPTER 13 EXECUTION OF SAMPLE PROGRAM WITH CW-SIM</b>		<b>71</b>
13.1	VxWorks Network Daemon Startup .....	71
13.2	Creating Simulator .....	71
13.3	Simulator Settings .....	73
13.4	Execution of Sample Program .....	74
<hr/> <b>CHAPTER 14 EXECUTION OF PROGRAM WITH CW-SIM STANDALONE</b>		<b>76</b>
14.1	VxWorks Network Daemon Startup .....	76
14.2	Simulator Startup .....	77
<hr/> <b>CHAPTER 15 TROUBLESHOOTING</b>		<b>79</b>
15.1	Installation .....	80
15.2	Installation Using Temporary License .....	82
15.3	License .....	83
15.4	Simulator Startup .....	84

---

APPENDIX 86

---

Appendix 1 VxWorks Component List ..... 86

    Appendix 1.1 VxWorks 6.8 component list (Q24DHCCPU-V) ..... 86

    Appendix 1.2 VxWorks 6.4 component list (Q12DCCPU-V) ..... 87

Appendix 2 QBF\_Simulator Bus Interface Functions (Stub) ..... 88

Appendix 3 Support ..... 91

    Appendix 3.1 Technical support assistance service regarding C Controller module ..... 91

---

INDEX 92

---

REVISIONS ..... 94



# MANUAL PAGE ORGANIZATION

The following illustration is for explanation purpose only, and should not be referred to as an actual documentation.

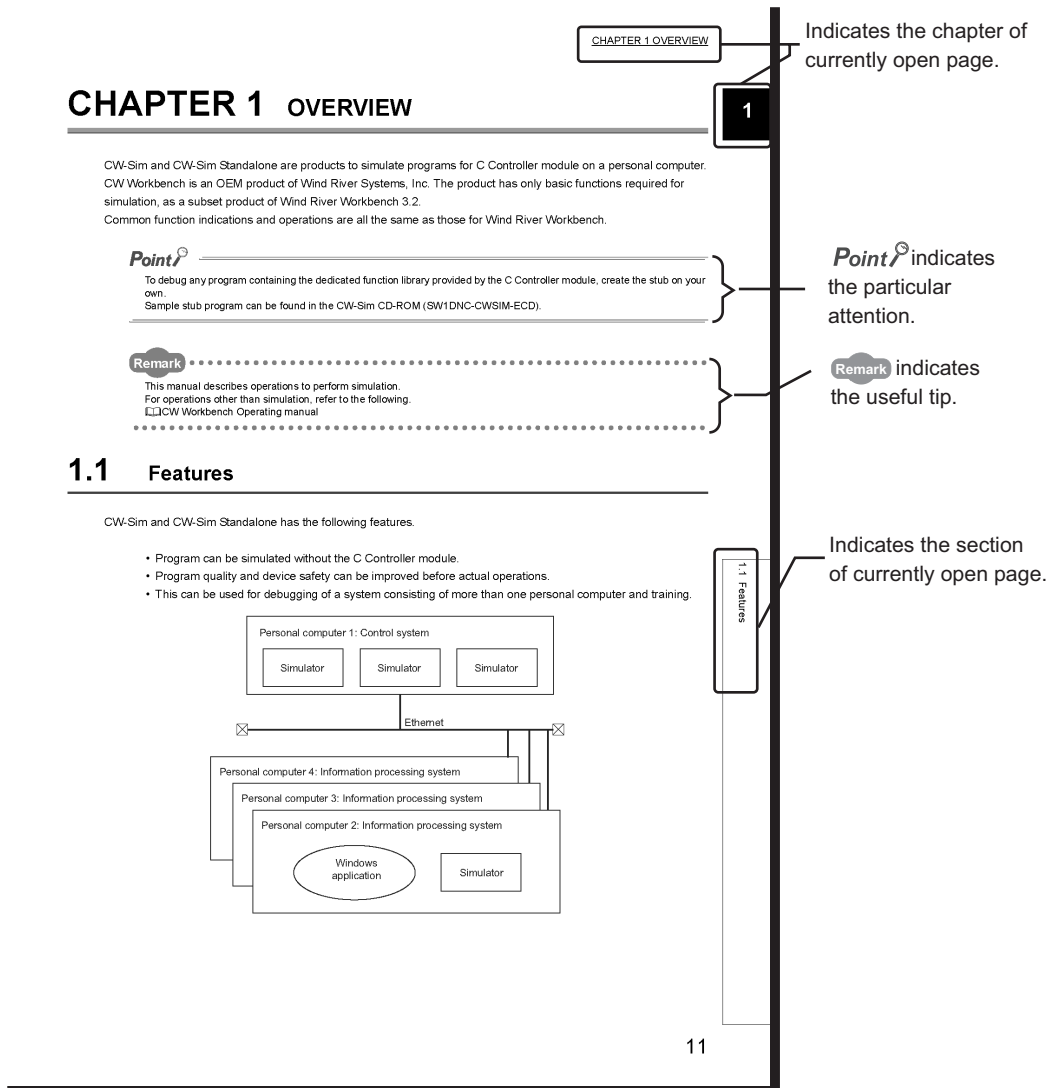

Operating procedures

Two styles of descriptions are used in this manual as below:

## (1) When there is only one operation

- Menu bar [File] ⇒ [New]

## (2) When there are steps

1. Select [Start] ⇒ [All Programs] ⇒ [Wind River] ⇒ [CW Workbench] ⇒ [CW Workbench].
2. Specify a folder of storage location of workspace for "Workspace:".

Symbols used in this manual

The following shows the symbols used in this manual with descriptions and examples.

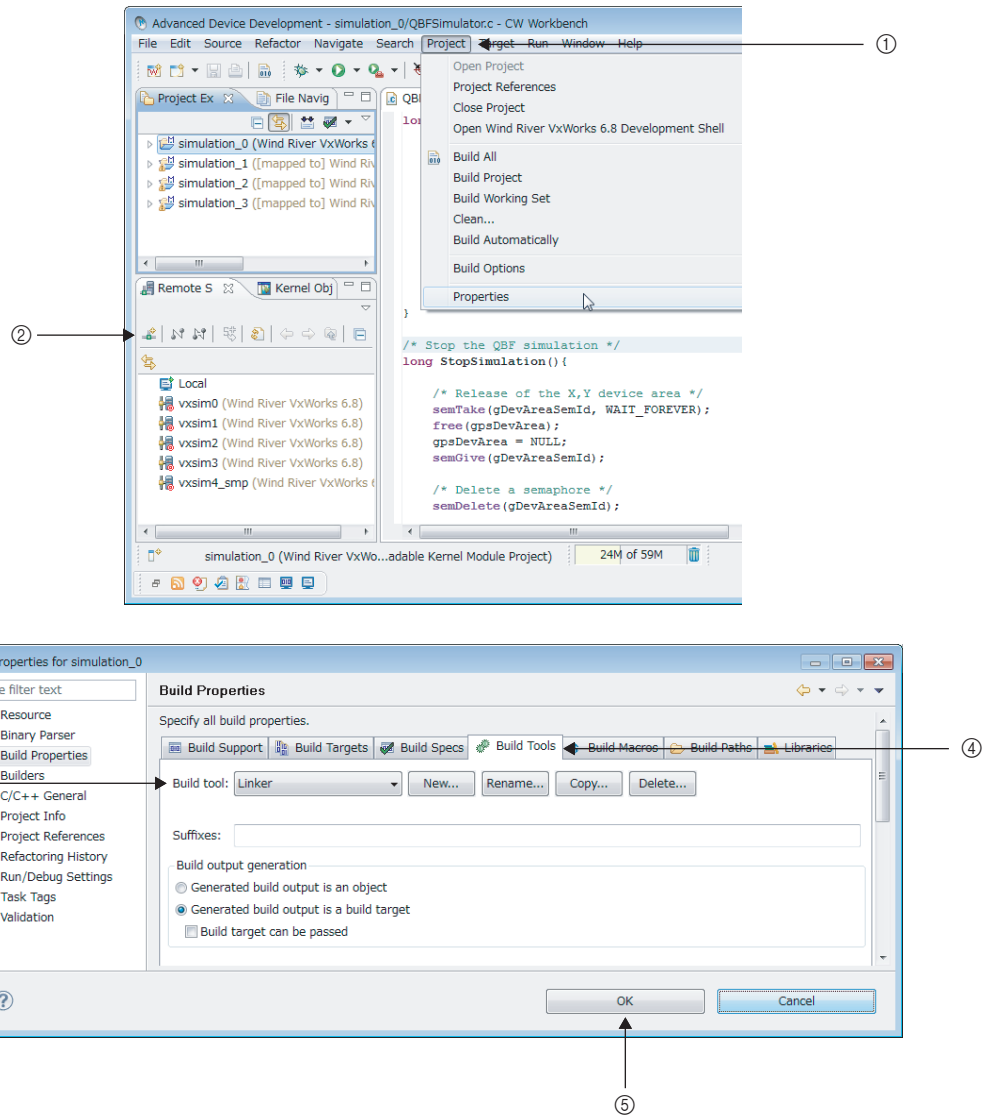

No.	Symbol	Description	Example
①	[     ]	Menu name on a menu bar	[Project]
②		Toolbar icon	
③	" "	Screen name or item name on a screen	"Build tool:"
④	<< >>	Tab name on a screen	<<Build Tools>>
⑤		Button on a screen	
-		Keyboard key	
-		Reference page	-
-		Reference manual	-

# GENERIC TERMS AND ABBREVIATIONS

Unless otherwise specified, this manual uses the following generic terms and abbreviations.

Generic term/abbreviation	Description
Q24DHCCPU-V	The abbreviation for Q24DHCCPU-V C Controller module.
Q12DCCPU-V	The abbreviation for Q12DCCPU-V C Controller module.
C Controller module	The generic term for Q24DHCCPU-V C Controller module and Q12DCCPU-V C Controller module.
SW4PVC-CCPU	The abbreviation for the C Controller setting and monitoring tool (SW4PVC-CCPU).
SW3PVC-CCPU	The abbreviation for the C Controller setting and monitoring tool (SW3PVC-CCPU).
Wind River Workbench	The generic term for Wind River Workbench manufactured by Wind River Systems, Inc.
CW Workbench	The engineering tool for C Controller module. The generic term for OEM products of Wind River without the runtime analysis tool and simulation functions (VxSim) of Wind River Workbench; a subset of Wind River Workbench.
VxSim	The generic term for the VxWorks simulator functions of Wind River's Workbench.
CW-Sim	The abbreviation for the VxWorks simulator that can operate the C Controller module program on a personal computer with CW Workbench installed, without connecting to the actual machine (target).
CW-Sim Standalone	The abbreviation for the VxWorks simulator that can operate C Controller module program even on a personal computer without CW Workbench installed.
RTP	The abbreviation for Real Time Process Project, one of the project types of Wind River's Workbench. RTP is a process executed on the VxWorks real time processor that creates VxWorks 6.x user mode applications.
Personal computer	The generic term for personal computers where Windows® operates.

## TERMS

Unless otherwise specified, this manual uses the following terms.

Term	Description
Dedicated function library	The generic term for bus interface function, MELSEC data link function, and C Controller module-dedicated function.
Bus interface function	Dedicated function library offered by C Controller module. This function is used when executing the following: <ul style="list-style-type: none"> <li>• Input from or output to I/O modules controlled by the C Controller module</li> <li>• Access to the buffer memory of an intelligent function module</li> <li>• The readout or control of the C Controller module status</li> </ul>
MELSEC data link function	Dedicated function library offered by C Controller module. This function is used when writing to/reading from a device of other programmable Controller CPUs connected via network or configured with multiple CPUs.
C Controller module-dedicated function	Dedicated function library that controls C Controller module. This function is used when reading the C Controller module status, controlling LED, and accessing to resources such as time and battery backup RAM.

# CHAPTER 1 OVERVIEW

---

CW-Sim and CW-Sim Standalone are products to simulate programs for VxWorks system on a personal computer. CW-Sim and CW-Sim Standalone is an OEM product of Wind River Systems, Inc. The product has only basic functions required for simulation, as a subset product of Wind River Workbench 3.2. Indications and operations of the common functions are all the same as those for Wind River Workbench.

## Point

To debug any program containing the dedicated function library provided by C Controller module, create the stub on your own.  
The sample stub program can be found on the CW-Sim CD-ROM (SW1DNC-CWSIM-ECD).

---

## Remark

This manual describes operations to perform simulation.  
For operations other than simulation, refer to the following manual.  
 CW Workbench Operating manual

---

## 1.1 Features

---

CW-Sim/CW-Sim Standalone has the following features.

- VxWorks system can be simulated without the C Controller module.
- The program quality and device safety can be improved before actual operations.
- This product can be used for debugging of a system consisting of more than one personal computer and training.

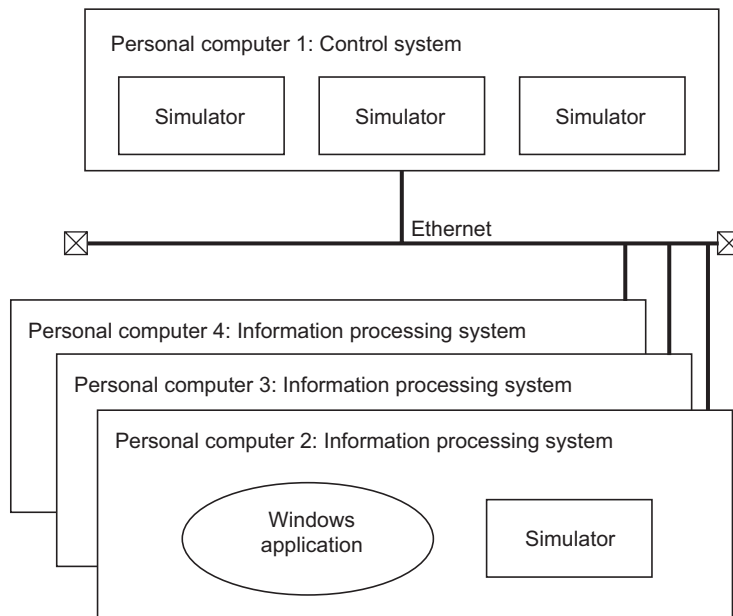

- The difference between CW-Sim and CW-Sim Standalone is described below.

CW-Sim	CW-Sim Standalone
Programs can be simulated and debugged on a personal computer with CW Workbench installed.	Programs can be simulated on a personal computer without CW Workbench installed, but programs cannot be debugged.

- The differences between CW-Sim, CW-Sim Standalone, and Wind River's Wind River Workbench simulator functions (VxSim) are described below.

○: Available, —: Unavailable

Item	Function	Description	CW-Sim	CW-Sim Standalone	VxSim
Introduction and management	Install and Uninstall	Installation and uninstallation by the wizard.	○*1	—	○
	License management	License key authentication	○	—	○
Compiler	Diab compiler	Build as Wind River compiler by SIMNTdiab	—	—	○
	GNU compiler	Build as Wind River GNU compiler by SIMNTgnu	○	—	○
Startup	Start script	Script is executed at startup.	○	○	○
VxWorks function	Real Time Process (RTP)	Program(s) required for Real Time system are executed.	—	—	○
	Multi tasking	System functions including task management, inter-task communication and event transmission/reception are used.	○	○	○
	POSIX standard interface	Interface specified for IEEE Std 1003.1 (base standard) is used.	○	○	○
	I/O system	Standard interfaces are used for access to various devices.	○	○	○
	Local file system	MS-DOS-compatible file system (dosFs) is used.	○	○	○
	Error detection and reporting	Software failure debugging	○	○	○
	Shared data area	Memory is mutually shared between processes.	—	—	○
	Shared library	Shared library containing codes and data is used.	—	—	○
	VxMP (Shared memory object)	Shared memory that realizes high-speed synchronization/communication between tasks executed on different CPUs is used.	—	—	○
	VxFusion (Distributed message queue)	Dispersion mechanism on different CPUs based on VxWorks message queue is used.	—	—	○
Wind River System Viewer	System Viewer command server of VxWorks is used.	—	—	○	
Simulated hardware	VxWorks console	Shell console by VxWorks system tasks is used.	○	○	○
	System timer	Timer generated from core clock used in VxWorks is used.	○	○	○
	Memory Management Unit (MMU)	Virtual memory is managed independent of MMU architecture of CPUs.	○	○	○
	Non-volatile RAM (NVRAM)	Non-volatile RAM areas are simulated.	○	○	○
	Virtual disc support	Disc block device is simulated.	○	○	○
	Time stamp driver	Wind River System Viewer is used to display time frame.	—	—	○
	Real time clock	Time and calendar are updated and controlled.	○	○	○
Virtual network	Link to virtual network and external network by network daemon	○	○	○	

\*1: CW-Sim is also uninstalled by the CW Workbench uninstaller.

# CHAPTER 2 SYSTEM CONFIGURATION

This section explains the system configuration of CW-Sim and CW-Sim Standalone.

## 2.1 Device Configuration

A simulation environment for CW-Sim can be established by installing CW Workbench and CW-Sim to the personal computer.

A simulation environment for CW-Sim Standalone can be established by the execution file of CW-Sim Standalone<sup>\*1</sup> and VxWorks image/symbol files<sup>\*2</sup>.

\*1 : CW-Sim Standalone's execution file can be copied from CW-Sim Standalone CD-ROM (SW1DNC-CWSIMSA-ECD).

\*2 : VxWorks image/symbol files can be copied from CW-Sim CD-ROM (SW1DNC-CWSIM-ECD).

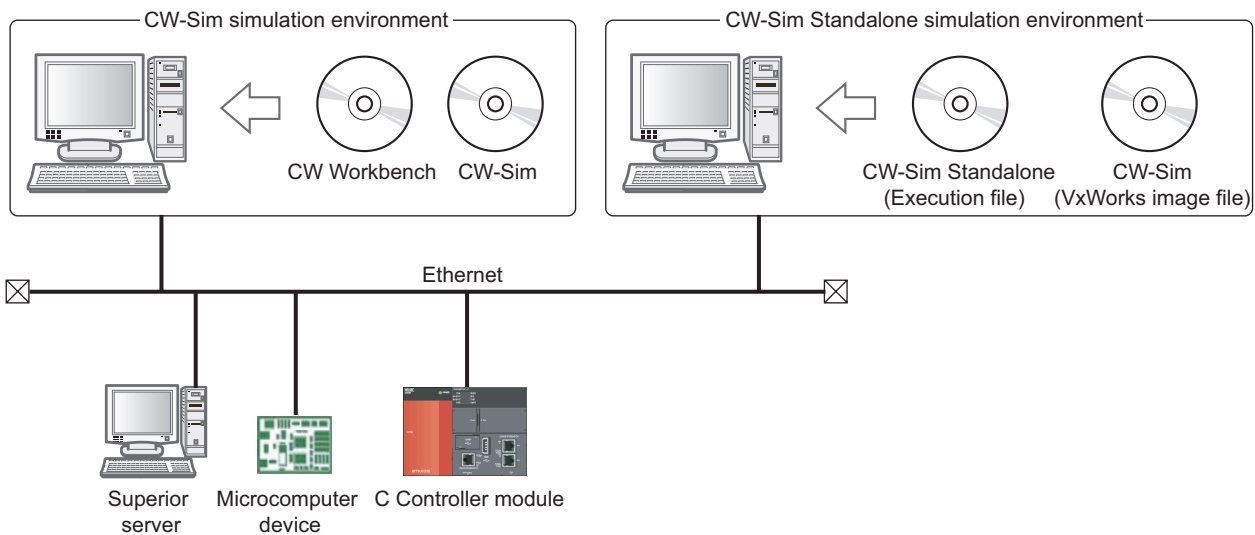

Programs running on the simulator can be interlocked with superior server, microcomputer device, and C Controller module via Ethernet.

## 2.2 Communication Paths Available for CW-Sim/CW-Sim Standalone

This section explains the communication paths available for applications running on the simulator.

### (1) Between the simulators on the same personal computer

**Example** The path ① in the following figure

### (2) Between the simulator and the other application on the same personal computer

**Example** The path ② in the following figure

### (3) Between the simulator and other applications on a different personal computer

**Example** The path ③ in the following figure

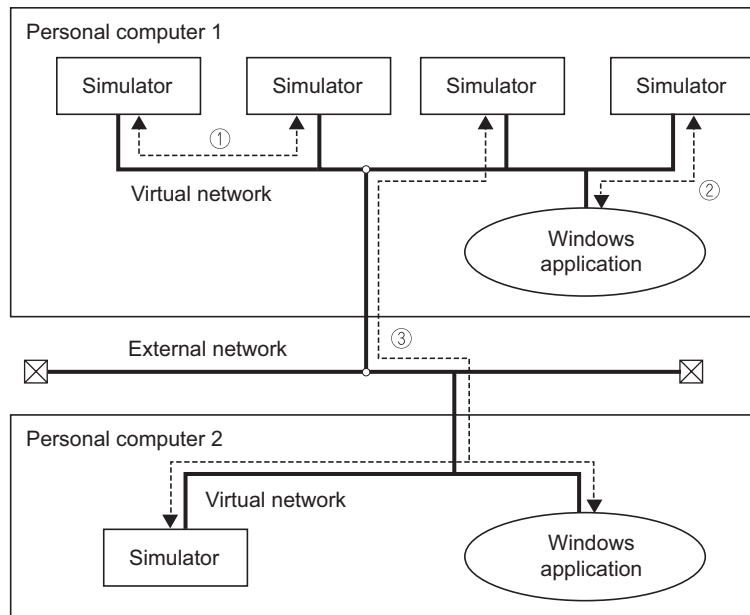

The following are the specifications of the sample program stored on the CW-Sim CD-ROM (SW1DNC-CWSIM-ECD).

- 4 programs are simulated on 1 personal computer.
- A program communicates with other programs via the virtual network.
- Dedicated library functions called by the programs execute functions in the stub (QBF\_Simulator.c) to perform simulation.

## 2.3 Relevant Modules

The following modules are supported by CW-Sim and CW-Sim Standalone.

Module model name	Operating system type
Q24DHCCPU-V	VxWorks 6.8
Q12DCCPU-V	VxWorks 6.4

# CHAPTER 3 OPERATING ENVIRONMENT

Below is a list of the operating environment of a personal computer where CW-Sim and CW-Sim Standalone can be operated.

Item	Description
Computer	PC/AT-compatible personal computer in which the following operating systems can be operated.
CPU	Intel® Core™2 Duo 2GHz or higher is recommended.
Memory requirements	1G byte or more (2G bytes or more is recommended)
Hard disk space	Install size: HDD 4G bytes or more Executable size: Virtual memory 512MB or more
Display	1024-by-768 resolution or higher
Disk drive	CD-ROM drive
Interface	Ethernet 10BASE-T/100BASE-TX/1000BASE-T
Operating system *1,*2,*3,*4	<ul style="list-style-type: none"> <li>• Microsoft® Windows® 7 Professional (Japanese/English)*5</li> <li>• Microsoft® Windows® 7 Ultimate (Japanese/English)*5</li> <li>• Microsoft® Windows® 7 Enterprise (Japanese/English)*5</li> <li>• Microsoft® Windows Vista® Business (Japanese/English) Operating System</li> <li>• Microsoft® Windows Vista® Ultimate (Japanese/English) Operating System</li> <li>• Microsoft® Windows Vista® Enterprise (Japanese/English)</li> <li>• Microsoft® Windows® XP Professional (Japanese/English) Operating System Service Pack3 or later</li> </ul>

\*1 : A 64-bit operating system is not supported.

\*2 : The following functions cannot be used.

Using the following functions may lead to improper operation of CW-Sim/CW-Sim Standalone.

- Application execution in Windows® Compatibility Mode
- Fast User Switching
- Remote Desktop
- Large fonts (detailed setting in the screen properties)
- DPI setting other than 100%

\*3 : Log on as a user with the Administrator attribute when installing and uninstalling CW-Sim.

\*4 : TCP/IP is required.

\*5 : The following function cannot be used:

- Windows® XP Mode



# CHAPTER 4 SPECIFICATIONS

## 4.1 Specifications of CW-Sim and CW-Sim Standalone

Below are specifications of CW-Sim and CW-Sim Standalone.

Item	Specifications	
	CW-Sim	CW-Sim Standalone
Product name	CW-Sim	CW-Sim Standalone
Operating system of applicable host machine	Refer to "Operating environment" (☞ Page 14, CHAPTER 3)	
Applicable C Controller module	Refer to "Relevant Module" (☞ Page 13, Section 2.3)	
Building	GNU compiler (SIMNTgnu)	—
License format	Node locked	Runtime
Document	Wind River VxWorks Simulator Help document	

## 4.2 Differences from C Controller Module

This section explains differences from C Controller module that should be considered in user program development for using CW-Sim and CW-Sim Standalone.

### (1) Floating point function

The hardware floating point function is not supported.  
Use the following ANSI floating point function.

#### Available ANSI floating point function\*1

acos(), asin(), atan(), atan2(), cos(), cosh(), exp(), fabs(), floor(), fmod(), log(), log10(), pow(), sin(), sinh(), sqrt(), tan(), tanh()

\*1 : If any ANSI floating point function other than those listed above is used, a symbol error occurs in loading.

### (2) C Controller module dedicated function library

The dedicated function library (Bus interface function, MELSEC data link function, and C Controller module-dedicated function) cannot be simulated.

To debug any program containing these functions, create a stub or delete the caller.

#### Remark

For more information, refer to the following manual that can be found on the CW-Sim CD-ROM (SW1DNC-CWSIM-ECD).  
☞ Wind River VxWorks Simulator User's Guide

# CHAPTER 5 PACKING LIST

## 5.1 Packing List

The following items are included with CW-Sim and CW-Sim standalone.  
Check that all the items are included before use.

### (1) Items included

Model name	Item	Qty.
SW1DNC-CWSIM-E (CW-Sim product with license)	CD-ROM (SW1DNC-CWSIM-ECD)	1
	Before Using the Product	1
	License Certificate	1
	End-User Software License Agreement	1
	Permanent License Application Form (sample)	1
SW1DNC-CWSIM-EZ (CW-Sim product with additional license*1)	Before Using the Product	1
	License Certificate	1
	End-User Software License Agreement	1
	Permanent License Application Form (sample)	1
SW1DNC-CWSIMSA-E (CW-Sim Standalone)	CD-ROM (SW1DNC-CWSIMSA-ECD)	1
	License Certificate	1
	End-User Software License Agreement	1

\*1 : The CD-ROM is not included with the additional license product.  
To install CW-Sim, the CD-ROM included with the CW-Sim product with license is required.

### (2) Contents of CW-Sim CD-ROM

Content	Description	Storage location
CW-Sim install image	An install image file of CW-Sim	\ \images
VxWorks Image file Symbol file	VxWorks image file*1 and symbol file. • VxWorks 6.8: "vxWorks_6_8", "vxWorks_6_8.sym" • VxWorks 6.4: "vxWorks_6_4", "vxWorks_6_4.sym"	\VxWorks
Relevant document	Relevant manuals of VxWorks simulator and Wind River Workbench (PDF)	\docs
	A license notice (PDF) of the third party used in CW-Sim	\3rd_party_licensor_notices
Manual	CW-Sim Operating Manual (PDF)	\Manual\English
Permanent License Application Form	Application form for permanent license file acquisition and host machine transfer (PermanentLicenseApplicationForm.xls). This is used to apply for a permanent license and transfer of the host machine.	\
Sample program	A sample program for the simulator	\Samples\English

\*1 : The VxWorks image file contains Telnet and FTP services. To access these services, use the following account.  
(Account(s) can be added by using the loginUserAdd() function.)

- User name: target
- Password: password

**(3) Contents of CW-Sim Standalone CD-ROM**

Content	Description	Storage location
CW-Sim Standalone execution file	An execution file of CW-Sim Standalone	\CWSIMSA
Sample program	A sample program for the simulator	\Samples
Relevant document	A license notice (PDF) of the third party used in CW-Sim	\3rd_party_licensor_notices
Readme.txt	The ways to obtain the CW-Sim Operating Manual are described.	\

**5.2 Preparation before Using CW-Sim**

The following are the items to be prepared before using CW-Sim.

**(1) Development environment**

Prepare a personal computer with CW Workbench installed.

Enter the host name within 2 to 15 alphanumeric characters for a personal computer.

For required operating specifications of the personal computer, refer to the following section.

☞ Page 14, CHAPTER 3

**(2) CW-Sim CD-ROM (SW1DNC-CWSIM-ECD)**

Prepare the CW-Sim CD-ROM included with the product with license (SW1DNC-CWSIM-E).

The CD-ROM is required to install CW-Sim.

**(3) License Agreement**

An LAC described in the License Agreement is required to install CW-Sim by using a temporary license.

An LAC and a product ID described in the License Agreement are also required to apply for a permanent license.

Prepare the License Agreement included with CW-Sim.

**(4) Permanent license file**

A permanent license file is required to install CW-Sim by using a permanent license.

To acquire a permanent license file, use a Permanent License Application Form stored on the CW-Sim CD-ROM (SW1DNC-CWSIM-ECD) and send us the form.

**(5) Internet connection**

An Internet connection is required to install CW-Sim by using a permanent license.

Acquire a 31-day temporary license via the Internet.

## 5.3 Preparation before Using CW-Sim Standalone

---

The following are the items to be prepared before using CW-Sim Standalone.

### (1) Development environment

Enter the host name within 2 to 15 alphanumeric characters for a personal computer.

For required operating specifications of the personal computer, refer to the following section.

☞ Page 14, CHAPTER 3

### (2) CW-Sim Standalone CD-ROM (SW1DNC-CWSIMSA-ECD)

Prepare the CW-Sim CD-ROM included with the product with SW1DNC-CWSIMSA-E.

The CD-ROM is required to install CW-Sim standalone.

### (3) CW-Sim CD-ROM (SW1DNC-CWSIM-ECD)

Prepare the CW-Sim CD-ROM included with the product with license (SW1DNC-CWSIM-E).

This will be used to copy the VxWorks image/symbol files.

# CHAPTER 6 PROCEDURE OVERVIEW

## 6.1 From Installation of CW-Sim to Debugging of Programs

The following is the operating procedure from the installation of CW-Sim to the debugging of programs.

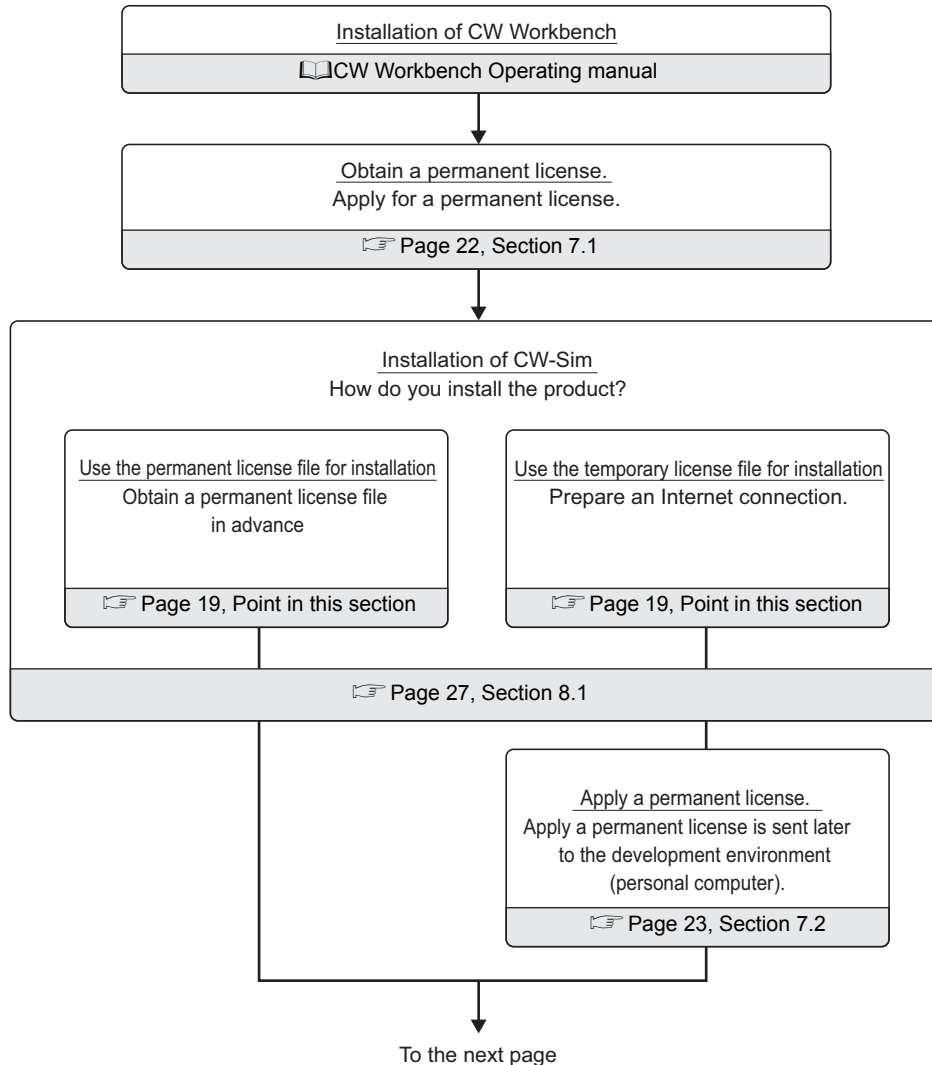

### Point

- **Installation using a permanent license**  
This installation is for users with a permanent license (regular license).  
All the functions of CW-Sim can be used for unlimited duration.
- **Installation using a temporary license**  
This installation is for users with a temporary license acquired on the Internet.  
All the functions of CW-Sim can be used for 31 days after the installation.

From the previous page



Apply a patch.  
Information and services  
For further information and services, please consult your local Mitsubishi representative.

👉 Page 37, CHAPTER 9

Set a VxWorks network daemon.  
Configure network settings to use the VxWorks network daemon.

👉 Page 40, CHAPTER 10

Create a project.  
Create a user program project and perform programming.

👉 Page 54, Section 11.1

Build.  
Build the user program.

👉 Page 64, Section 11.2

Debug.  
Debug the user program.

👉 Page 65, CHAPTER 12

## 6.2 From Installation of CW-Sim to Execution of Programs

The following is the operating procedure from the installation of CW-Sim Standalone to the execution of programs.

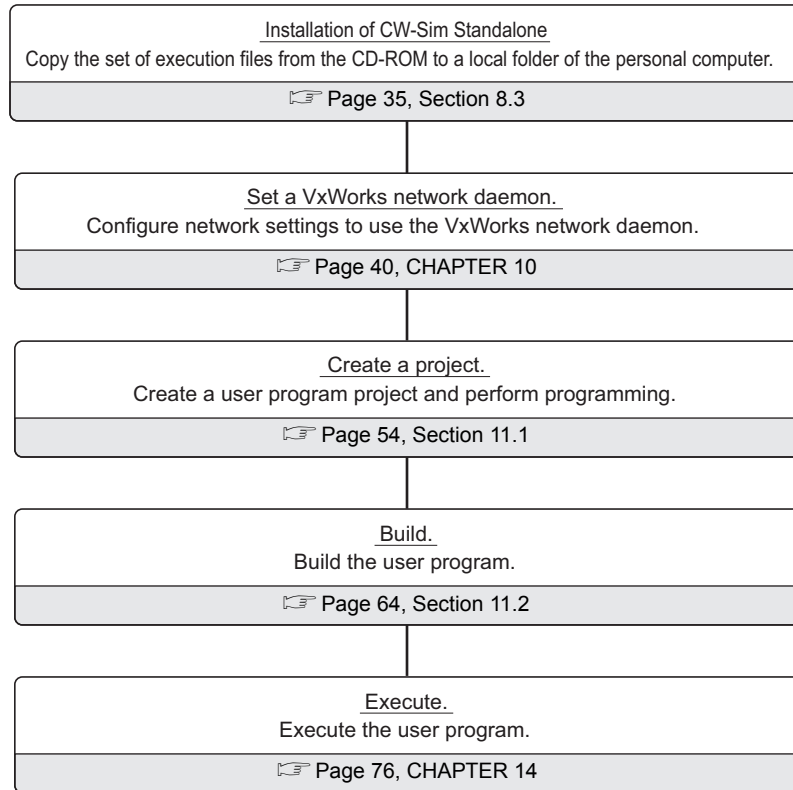

# CHAPTER 7 PERMANENT LICENSE

## 7.1 Obtaining Permanent License

A permanent license is required to use CW-Sim for unlimited duration. Follow the instructions shown below to obtain a permanent license.

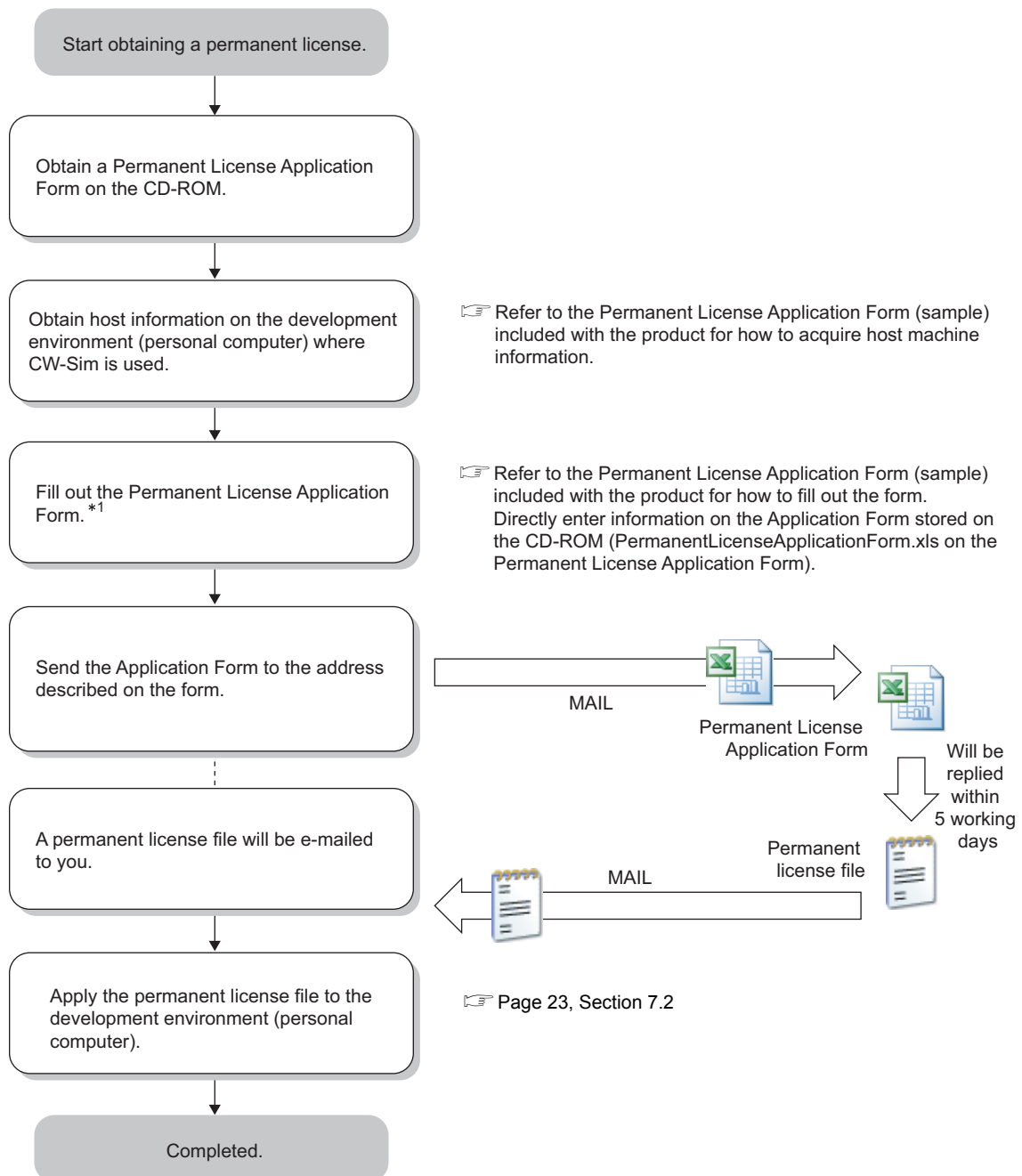



## 7.2 Applying Permanent License

Apply the acquired permanent license file to the personal computer specified for "Host machine information" on the application form.

Follow the instructions shown below to apply the permanent license file.

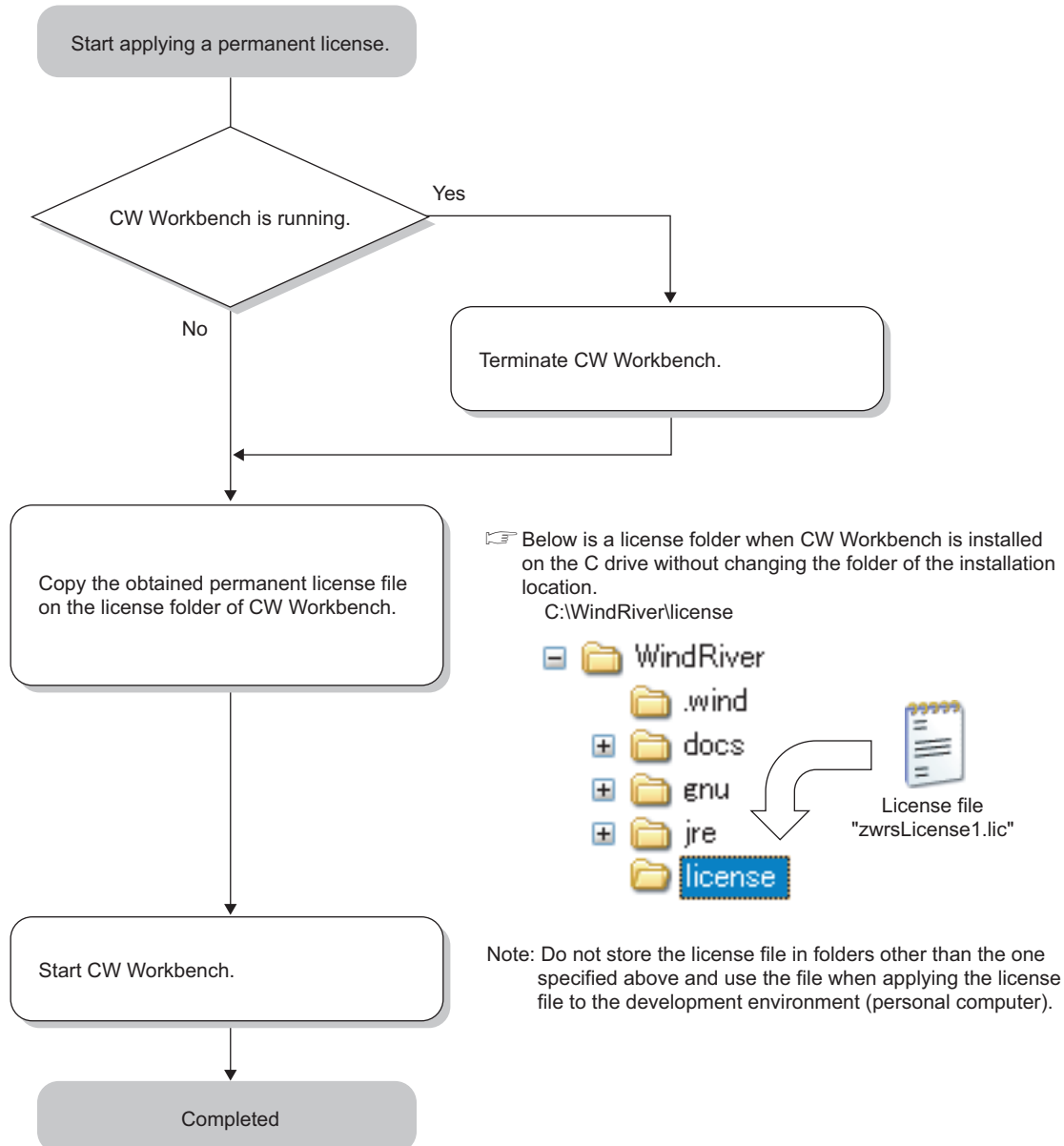

### Point

If "zwrLicense1.lic" already exists in the "license" folder, rename the file "zwrLicense1.lic" by incrementing the last number by 1.

**Example** "zwrLicense2.lic", "zwrLicense3.lic"...

# 7.3 Deleting Permanent License

Follow the instructions shown below to delete the current permanent license for license transfer.

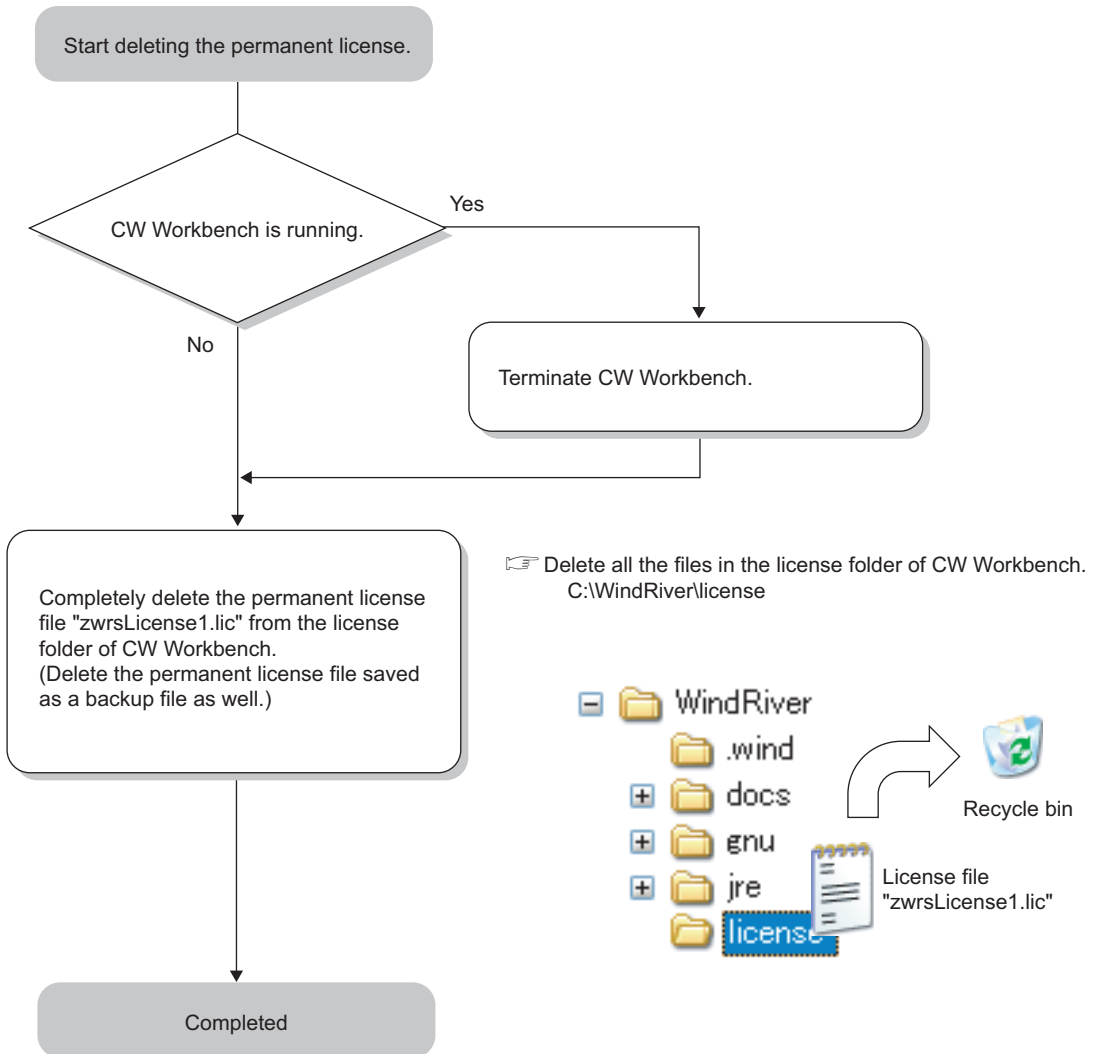

## 7.4 Re-applying Permanent License

Another permanent license is required on a new personal computer for license transfer due to reasons such as when the personal computer where CW-Sim has been installed crashed.

Follow the instructions shown below to re-apply a permanent license and transfer the host machine.

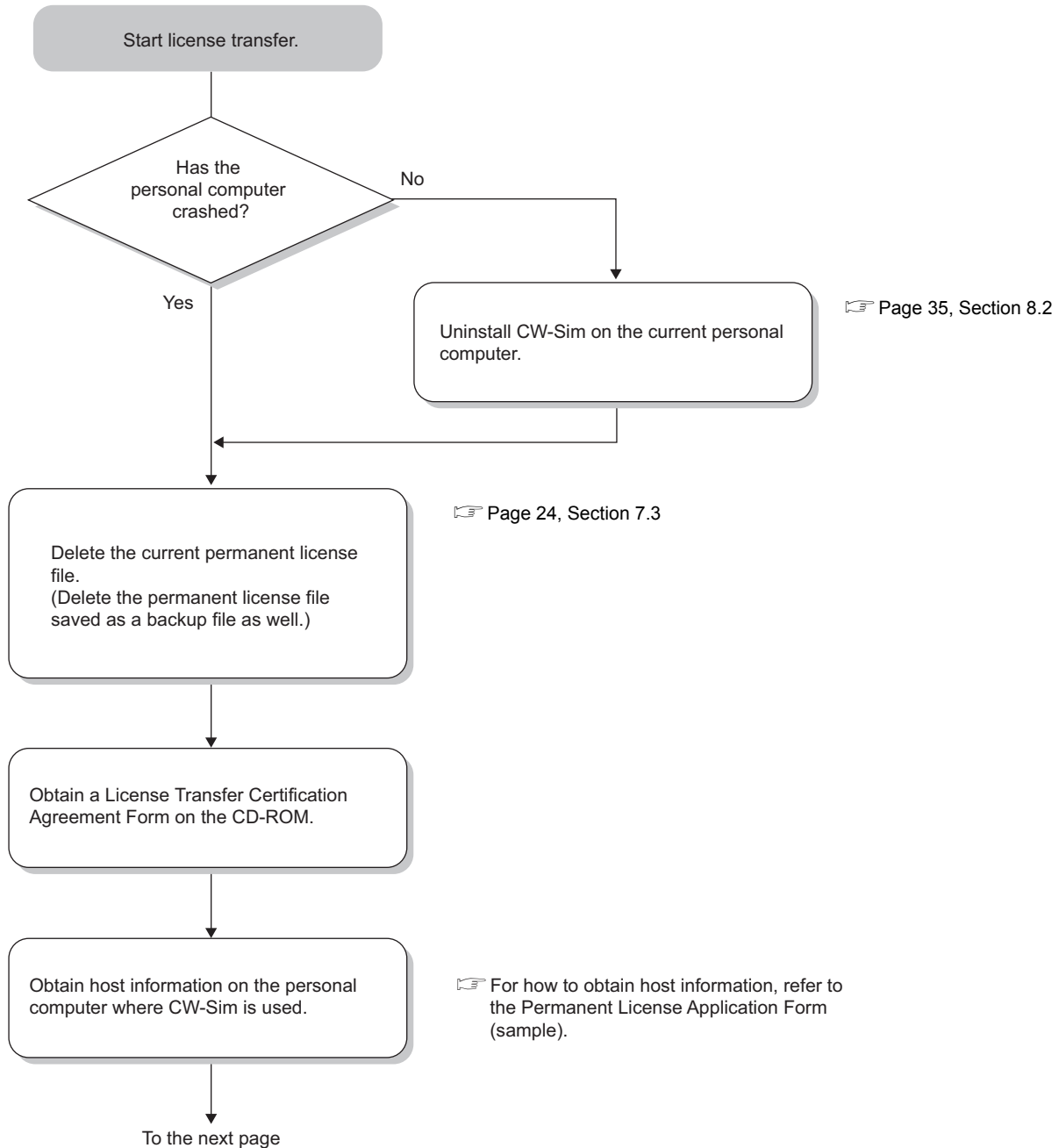

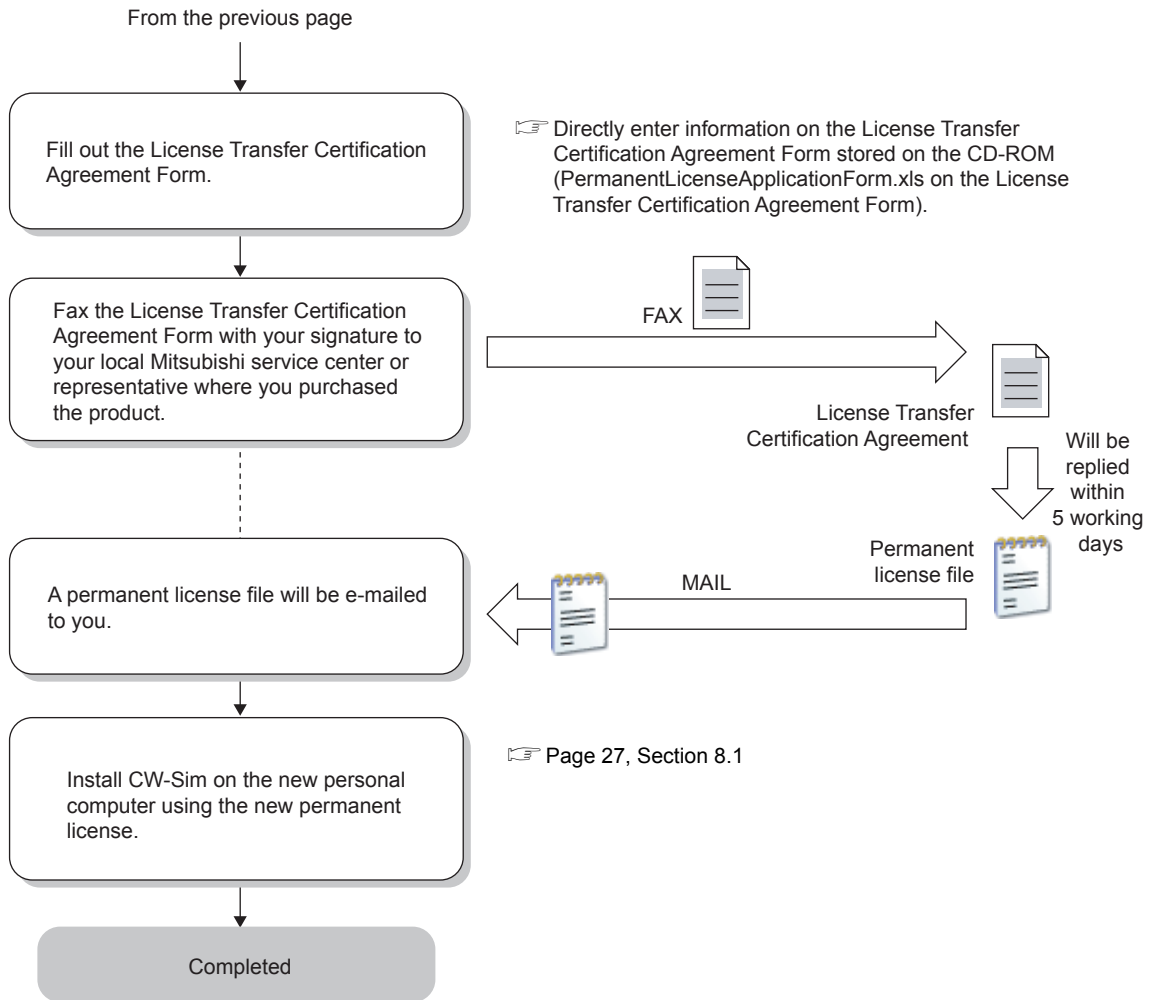

**Remark**

If you have lost the License Agreement and do not know the Product ID, contact your local Mitsubishi service center or representative and give them information filled out on the Permanent License Application Form.

- Name of the representative person, department name, and company name
- E-mail address
- Target CPU

# CHAPTER 8 INSTALLATION AND UNINSTALLATION

---

## 8.1 Installation of CW-Sim

---

This section explains how to install the product, how to operate, and precautions.

Unless operations differ depending on the operating system, windows and dialog boxes of Windows® 7 are used for explanations.

### 8.1.1 Preparation before installation

---

- (1) Log on as a user with the Administrator attribute.
- (2) Check CW Workbench is installed on the personal computer.
- (3) Insert the CD-ROM (SW1DNC-CWSIM-ECD) into the personal computer, the installer automatically starts.

If the installer does not automatically start, double-click "setup.exe" on the CD-ROM to start it.

#### *Point*

- Do not execute more than one "setup.exe" at the same time, or the product may not be properly installed.
  - If the installation was not completed properly, uninstall the product and execute "setup.exe" again.
-

**(4) For installation on Windows Vista® or Windows® 7, a dialog box asking whether to enable or disable User Account Control appears.**

Click "Allow" or "Yes" to continue the installation.

- For Windows Vista®

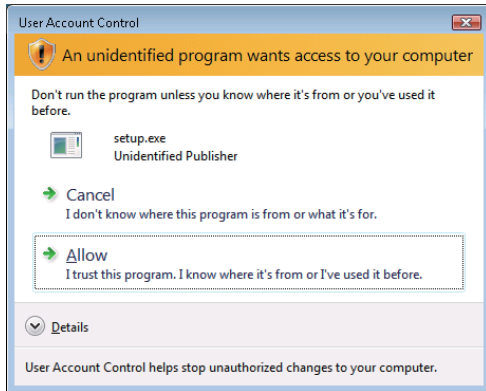

Click "Allow".

- For Windows® 7

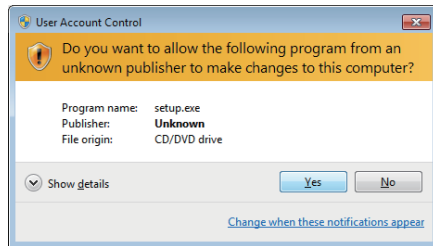

Click the  button.

---

**Point!**

- Stop all other applications running on Windows® before installation.
  - The installer may not operate the functions properly due to the automatic start of update programs of the operating system or any other software, such as Windows Update or Java Update. Change the setting to disable the automatic start of update programs before installation.
  - CW-Sim cannot be overwritten by installation. To uninstall it, uninstall CW Workbench first. Reinstall CW Workbench and then install CW-Sim.
  - To install CW-Sim using a temporary license, it can be obtained via the Internet. Before installation, check that the personal computer can be connected to the Internet.  
(If the personal computer is connected to the Internet via a proxy server, check the IP address and port number in advance. They are required to be set during installation.)  
Installation by a temporary license is not allowed without the Internet connection. Obtain the permanent license before installation. (📖 Page 22, Section 7.1)
-

## 8.1.2 How to install CW-Sim

Insert the CW-Sim CD-ROM (SW1DNC-CWSIM-ECD) into the CD drive to start the installer.

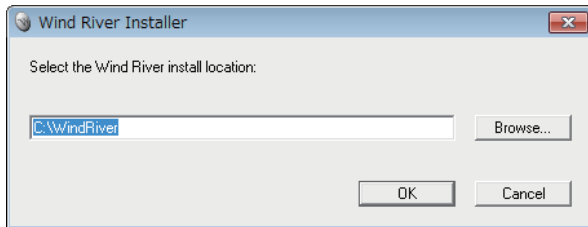

1. After the installer is started, execute one of the following operations and click the  button.

- Enter a folder name of the installation location.
- Click the  button to select a folder of the installation location from the tree view.

### Point

- About installation location  
For CW-Sim, select the same installation location as that of CW Workbench.

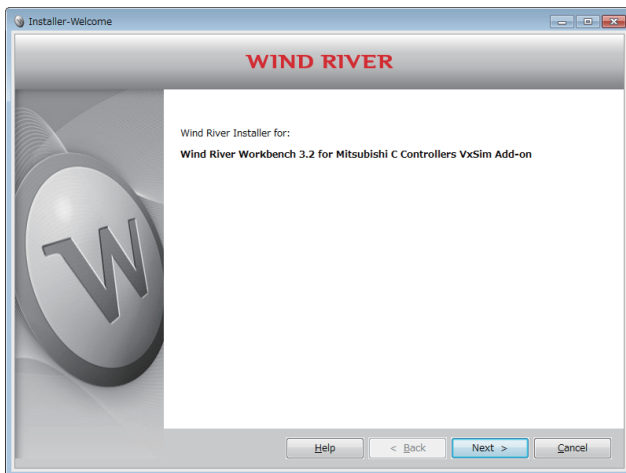

To the next page

2. Click the  button.

From the previous page

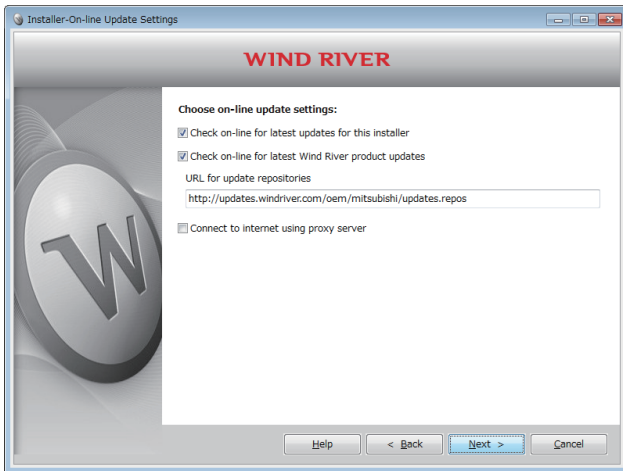

3. Click the **Next >** button.

### Point!

If the personal computer is connected to the Internet via a proxy server, check the box of "Connect to internet using proxy server" and configure the proxy server setting set for the Internet connection on the personal computer.

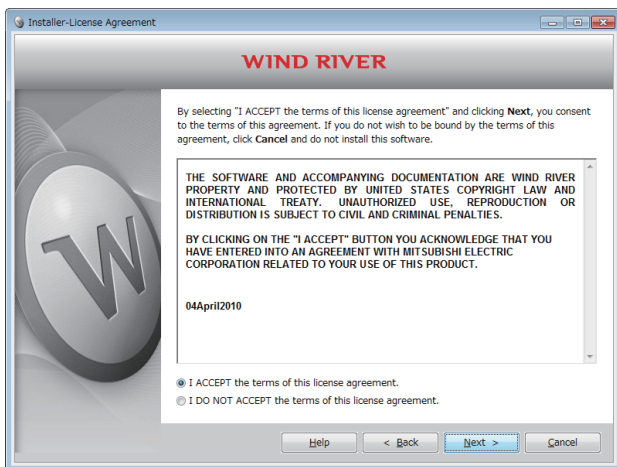
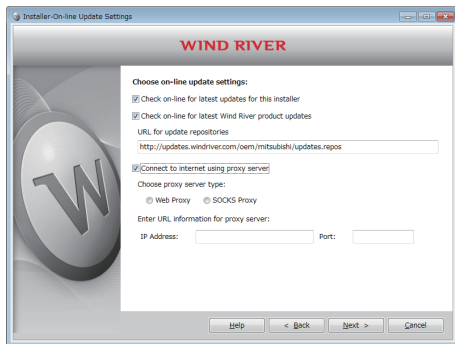

4. Select "I ACCEPT the terms of this license agreement." and click the **Next >** button.



To the next page



From the previous page



**5. To continue the installation, select one of the following procedures.**

If the permanent license file is not obtained

- **Installation using a temporary license (a personal computer can be connected to the Internet)**  
( Page 31 (1))

If the permanent license file is obtained

- **Installation using a permanent license**  
( Page 32 (4))

**Installation using a temporary license**

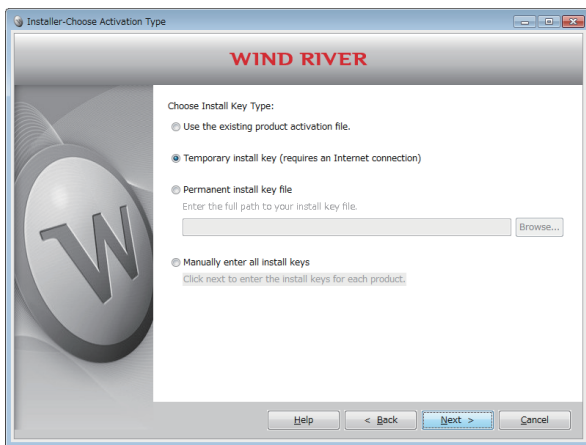

- (1) Select "Temporary install key (requires an Internet connection)" and click the button.

**Point**

- If "Temporary install key" is selected, the Internet is required to acquire "Temporary install key". Execute the installation on a personal computer connected to the Internet.
- If the personal computer is connected to the Internet via a proxy server, configure the proxy server setting. ( Page 30, Point in this section)  
If "Temporary install key" is selected without configuring the proxy server setting, installation does not proceed.

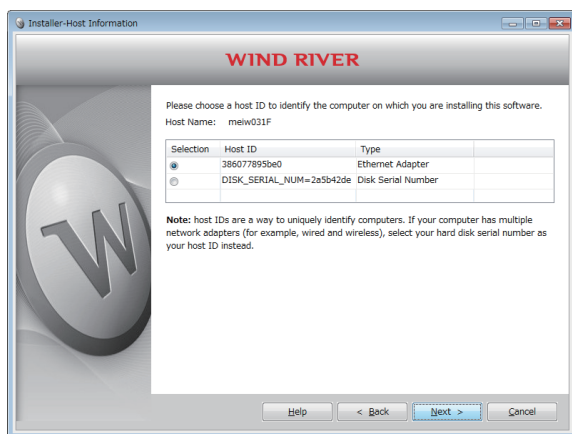

- (2) Check the content of "Note" on the window. Select either "Ethernet Adapter" or "Disk Serial Number" for the Host ID and click the button.



To the next page

From the previous page

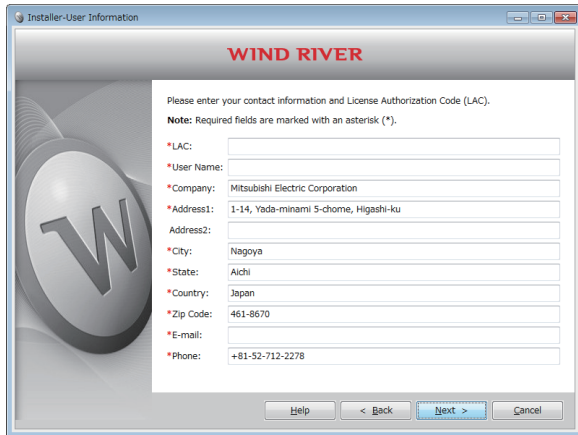

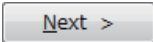
- (3) Enter a License Authorization Code (LAC) and user information listed below and click the  button.

### Point!

Use alphanumeric characters for the LAC and user information.  
(Items with a \* mark on the window must be entered correctly.)

LAC:	License Authorization Code (described in the License Agreement included with CW-Sim)
User Name:	User name
Company:	Company name
Address1:	Address (such as town name and block number)
Address2:	Building name, etc. (can be left blank)
City:	City
State:	State
Country:	Country
Zip Code:	Zip code
E-mail:	E-mail address
Phone:	Phone number



Go to the step 6 (  Page 33)

### Installation using a permanent license

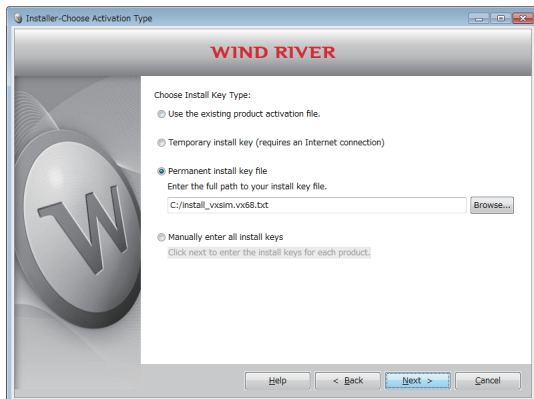

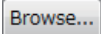
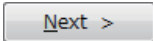
- (4) Select "Permanent install key file" and click the  button.  
Select the permanent license from the tree view. Then click the  button.



Go to the step 6 (  Page 33)

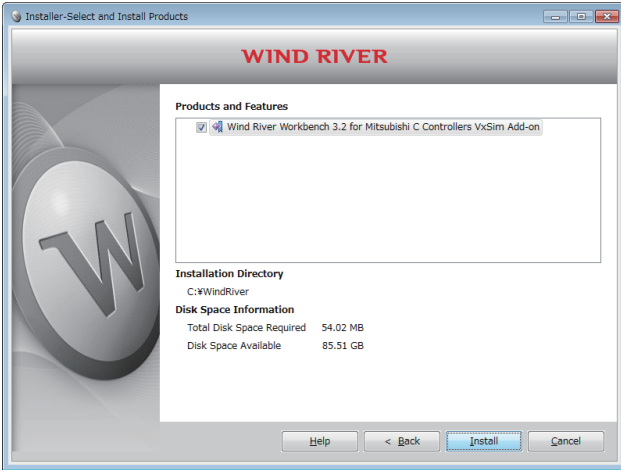

6. Check that all items are selected and click the

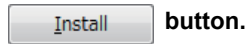

If the check box is  or , keep clicking the box until it changes to .

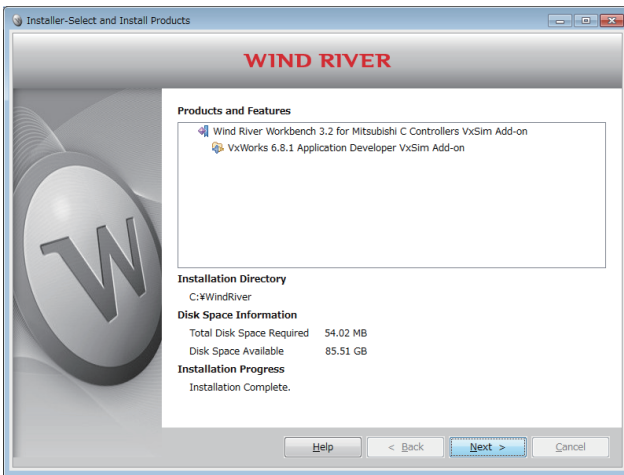

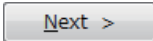
7. Click the  button.

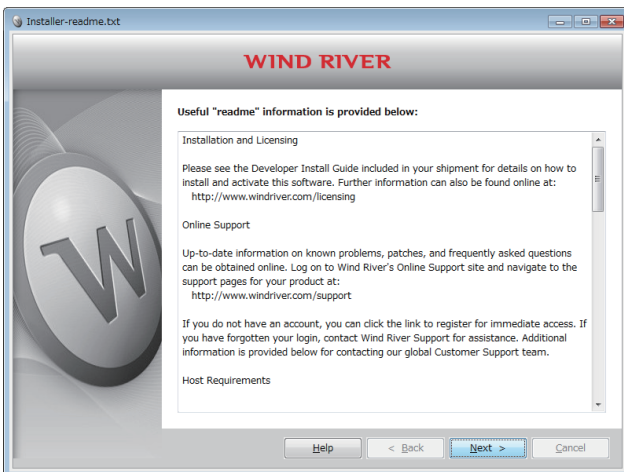

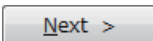
8. Click the  button.



To the next page

From the previous page

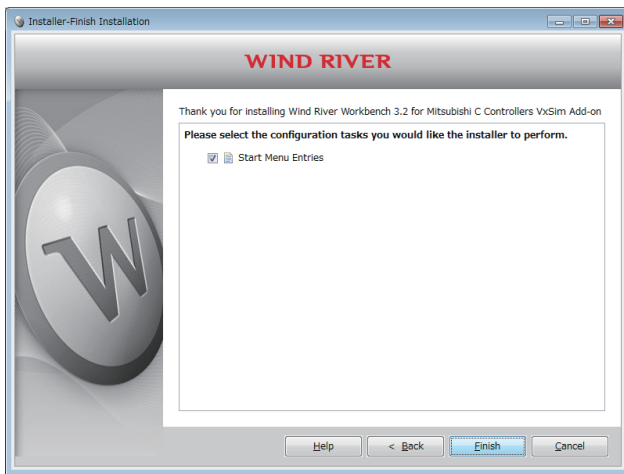

9. Click the **Finish** button.



Completed

## 8.1.3 Operations after installation

---

### (1) Copying VxWorks image/symbol files

Copy the VxWorks image/symbol files (☞ Page 16, Section 5.1 (2)) stored in the "VxWorks" folder on the CD-ROM (SW1DNC-CWSIM-ECD) to the local folder.

**Example** Destination local folder example

- C:\CCPUSIM

### (2) Registering with Exception List of Windows® Firewall

If Windows® Firewall is enabled, refer to the following section and check the settings.

☞ Page 85, Section 15.4 (4)

## 8.1.4 After installation

---

Once CW-Sim is installed, the following shortcut is registered with the Start menu.

- For Q24DHCCPU-V (VxWorks 6.8)  
[Start] ⇒ [All Programs] ⇒ [Wind River] ⇒ [Documentation] ⇒ [VxWorks 6.8]  
⇒ [VxWorks Simulator User's Guide, 6.8]

## 8.2 Uninstallation of CW-Sim

CW-Sim is also uninstalled when CW Workbench is uninstalled.  
(Uninstallation of CW-Sim alone is not allowed.)

### Point

- For CW Workbench uninstallation operations, refer to the following manual.  
📖 CW Workbench Operating Manual
- On the "Select features to uninstall" screen that appears in CW Workbench uninstallation operations, select all boxes as shown below.

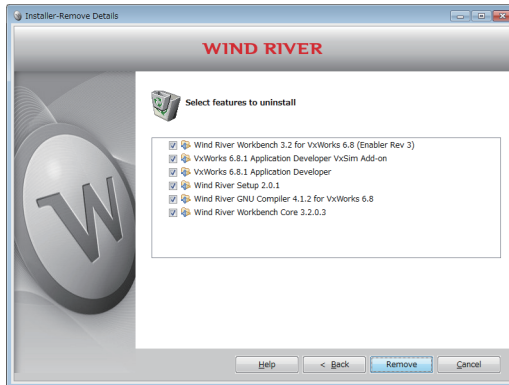

## 8.3 Installation of CW-Sim Standalone

The installer is not supplied with CW-Sim Standalone.  
Copy files from the following CD-ROM to the local folder.

**Example** Destination local folder example

- C:\CCPUSIM

### (1) CD-ROM (SW1DNC-CWSIMSA-ECD)

Copy the "CWSIMSA" and "Samples" folders (📁 Page 17, Section 5.1 (3)) to the local folder.

### (2) CD-ROM (SW1DNC-CWSIM-ECD)

Copy the VxWorks image/symbol files (📁 Page 16, Section 5.1 (2)) stored in the "VxWorks" folder to the local folder.

### (3) Registering with Exception List of Windows® Firewall

If Windows® Firewall is enabled, refer to the following section and check the settings.

📁 Page 85, Section 15.4 (4)

## 8.4 Uninstallation of CW-Sim Standalone

---

The uninstaller is not supplied with CW-Sim Standalone.  
Delete all files copied to the local folder.

# CHAPTER 9 APPLYING PATCH

This section explains how to apply a patch in case it is released.

Unless operations differ depending on the operating system, windows and dialog boxes of Windows® 7 are used for explanations.

## Point

- Log on as a user with the Administrator attribute.
- Terminate CW-Sim and CW Workbench before applying a patch.
- Do not stop the processing during patch application.  
Apply the patch again if the processing has been stopped.
- When a patch is applied on Windows Vista® or Windows® 7, a dialog box appears to enable or disable User Account Control. Click "Allow" or "Yes" to continue the application of the patch.

- For Windows Vista®

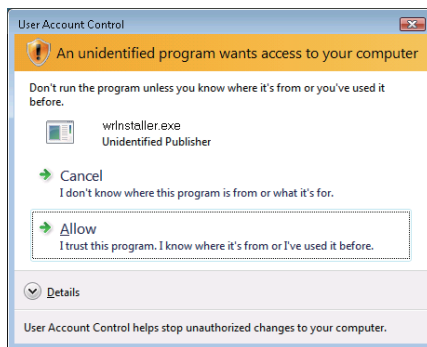

Click "Allow".

- For Windows® 7

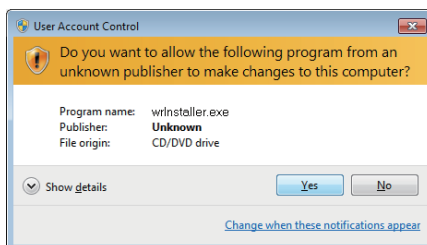

Click the  button.

## 9.1 How to Obtain Patch

---

### (1) Download a patch file from the site described below.

 Information and services

For further information and services, please consult your local Mitsubishi representative.

### (2) Extract the downloaded file and store it in the updates folder (in the folder of the installation location of CW-Sim).

**Example** When the installation location of CW-Sim is C:\WindRiver, the storage location of the patch is C:\WindRiver\updates.

## 9.2 How to Apply Patch

---

1. Select [Start] ⇒ [All Programs] ⇒ [Wind River] ⇒ [Product Maintenance] ⇒ [Installation at X YYYY].

### **Point**

- X and YYYY of [Installation at X YYYY] mean:  
X: The drive to which the product has been installed  
YYYY: The folder to which the product has been installed

**Example**

If the folder of the installation location specified at the time of installation is C:\WindRiver, the menu name is [Installation at C WindRiver].

---

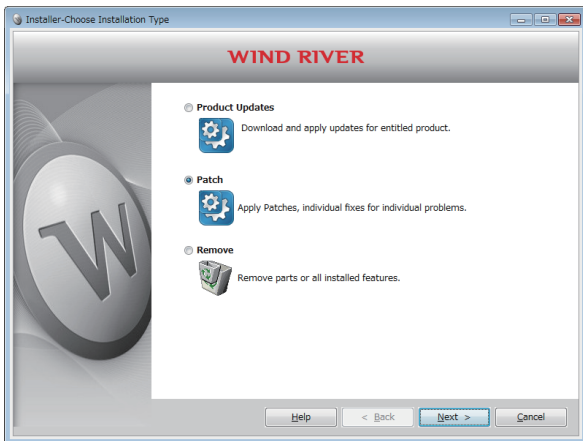

To the next page

2. Select "Patch" and click the  button.



From the previous page

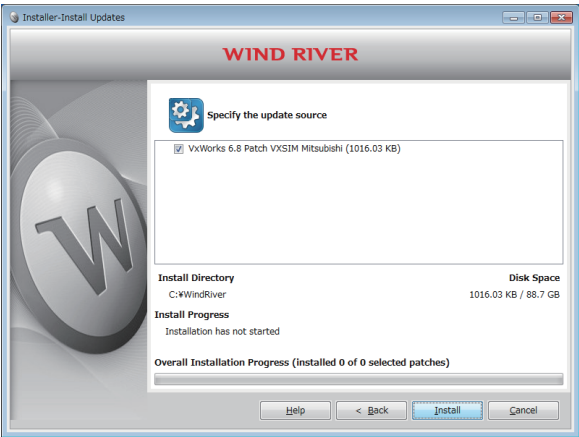

3. Check that the patch to be installed has been selected.

Click the  button.

**Point**

If the patch to be installed is not displayed, check whether the storage location of the patch file is correct.

- Patch file storage location  
 <Install folder for CW Workbench>\updates



4. Click the  button.



Completed

# CHAPTER 10 VxWorks NETWORK DAEMON SETTINGS

To use the VxWorks network daemon on the simulator, configure the following 3 settings.

1. Routing and Remote Access service setting
2. Network driver setting
3. TCP/IP setting

## 10.1 Windows® 7

### (1) Setting Routing and Remote Access service

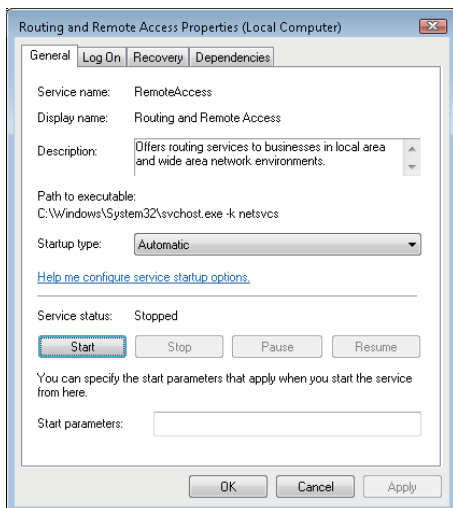

Completed

1. Select [Start] ⇒ [Control Panel] ⇒ [System and Security] ⇒ [Administrative Tools] ⇒ [Service], and double-click "Routing and Remote Access".
2. Select "Automatic" for "Startup type" and click the  button.
3. Click the  button.
4. When the "Service status" becomes "Start", click the  button.

## (2) Setting network driver

1. Select [Start] ⇒ [Control Panel] ⇒ [Hardware and Sound], and click "Device Manager".
2. Select "Network adapters" and click [Action] ⇒ [Add legacy hardware].

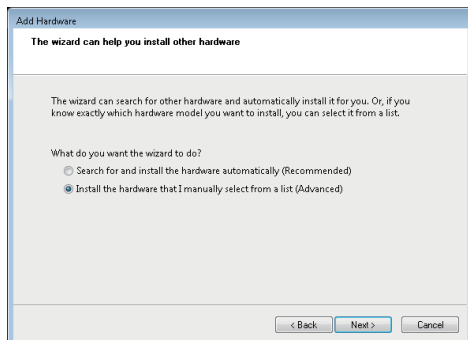
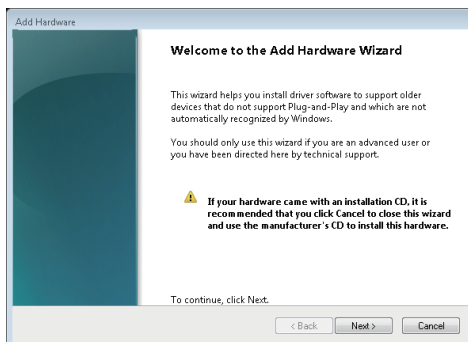
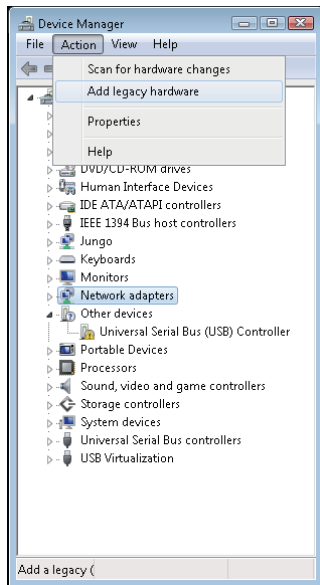



To the next page

3. Click the  button.

4. Select "Install the hardware that I manually select from a list (Advanced)" and click the  button.

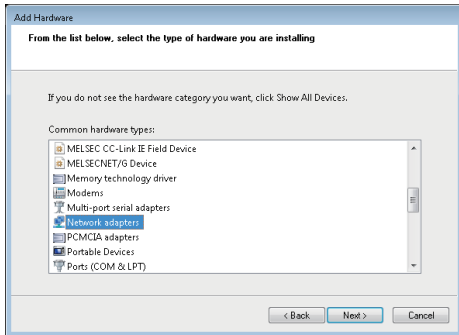
From the previous page



5. Select "Network adapters" and click the  button.

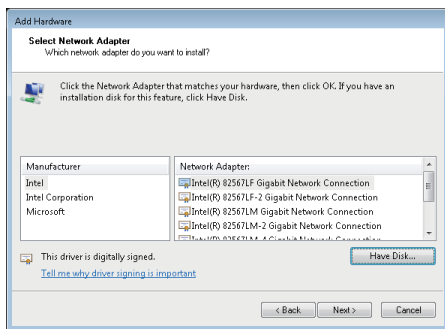

6. Click the  button.

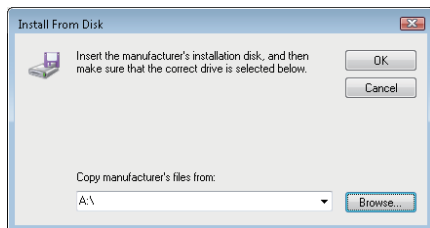



7. Click the  button.

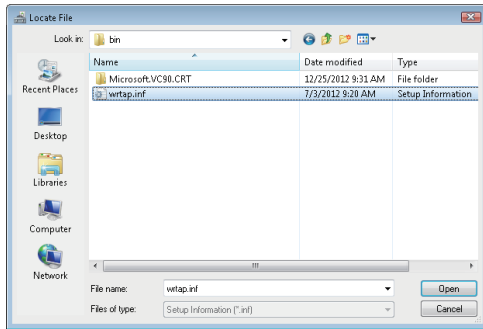

To the next page

From the previous page



8. Select "wrtap.inf" and click the  button.

10

**Remark**

- If the installation folder of CW-Sim is "C:\WindRiver", the folder for "wrtap.inf" is set as follows:
  - For Q24DHCCPU-V (VxWorks 6.8)
    - C:\WindRiver\vxworks-6.8\host\x86-win32\bin
  - For Q12DCCPU-V (VxWorks 6.4)
    - C:\WindRiver\vxworks-6.4\host\x86-win32\bin
- For CW-Sim Standalone, it is the local folder to which the files are copied. (☞ Page 35, Section 8.3)
  - When the local folder is "C:\CCPUSIM"
    - C:\CCPUSIM\CWSIMSA\vxsimnetd

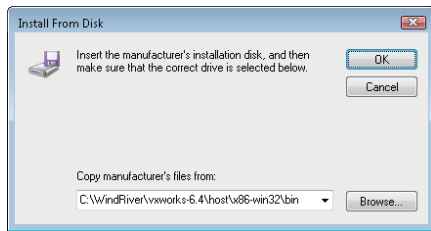

9. Click the  button.

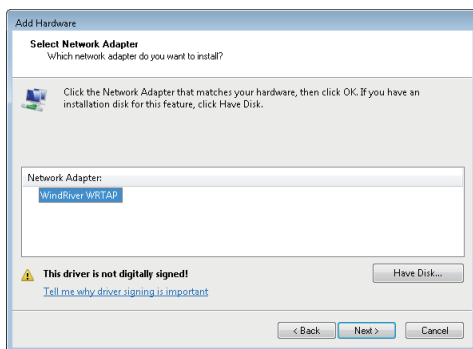

10. Select "WindRiver WRTAP" and click the  button.



To the next page

10.1 Windows® 7

From the previous page

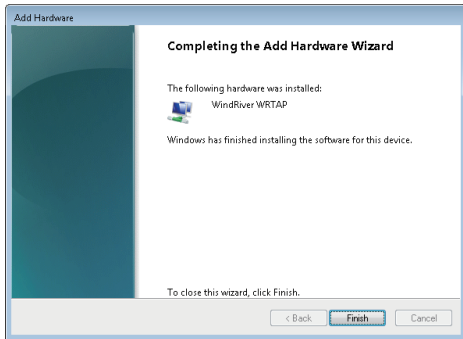
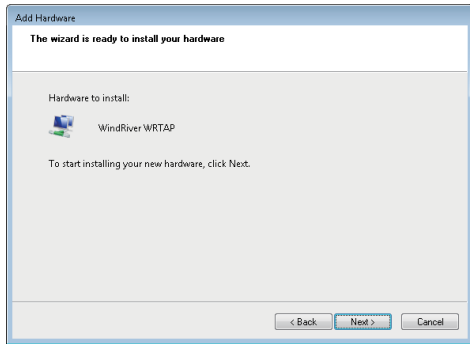

Completed

**11. Click the  button.**

If the following message box appears, click "Install this driver software anyway".

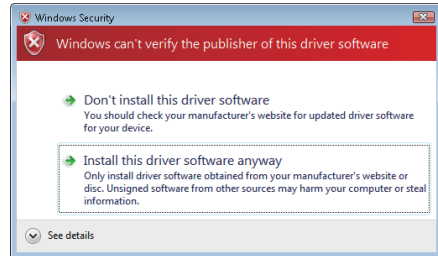

**12. Click the  button.**

### (3) Setting TCP/IP

1. Select [Start] ⇒ [Control Panel] ⇒ [Network and Internet] ⇒ [View network status and tasks], and click "Change adapter settings".

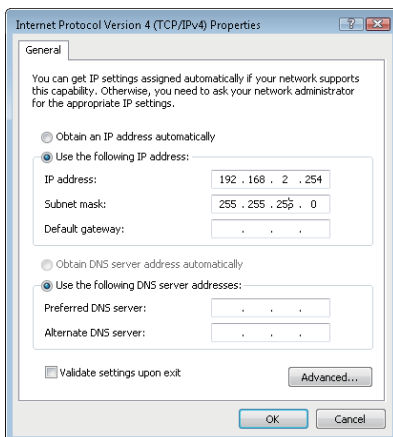
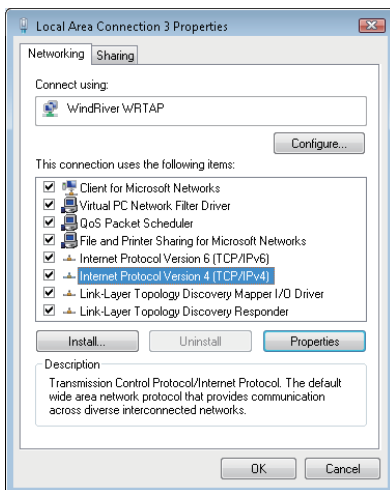
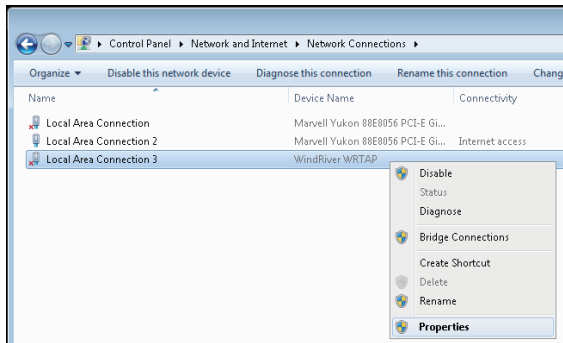

Completed

2. Click the local area connection with device name "WindRiver WRTAP". In the menu that pops up, select [Properties].
3. Select "Internet Protocol Version 4 (TCP/IPv4)" and click the  button.

4. Select "Use the following IP address:" and set "IP address" and "Subnet mask".



**Example** In this example, the following virtual network information is used.

IP address: 192.168.2.254  
Subnet mask: 255.255.255.0

5. Click the  button.

# 10.2 Windows Vista®

## (1) Setting Routing and Remote Access service

1. Select [Start] ⇒ [Control Panel] ⇒ [System and Maintenance] ⇒ [Administrative Tools] ⇒ [Service], and double-click "Routing and Remote Access".
2. Select "Automatic" for "Startup type" and click the  button.
3. Click the  button.
4. When the "Service status" becomes "Start", click the  button.

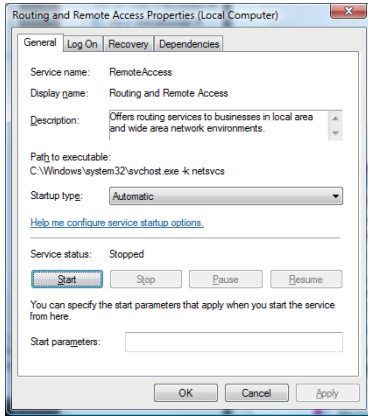

↓  
Completed

## (2) Setting network driver

1. Select [Start] ⇒ [Control Panel] ⇒ [Hardware and Sound], and click the "Device Manager".
2. Select "Network adapters" and click [Action] ⇒ [Add legacy hardware].

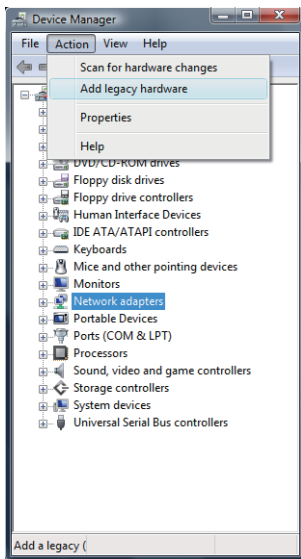

↓  
To the next page



From the previous page

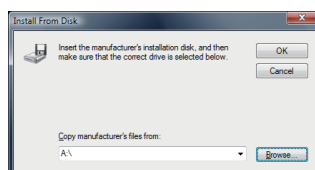
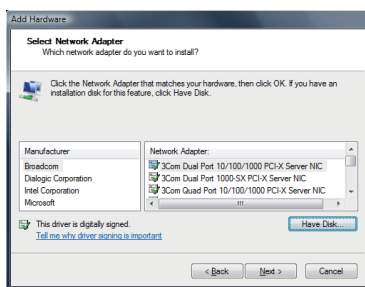
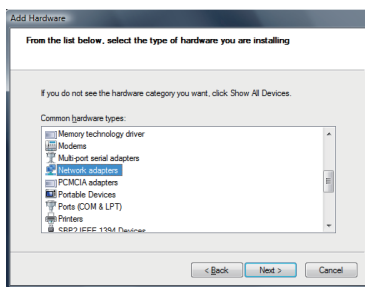
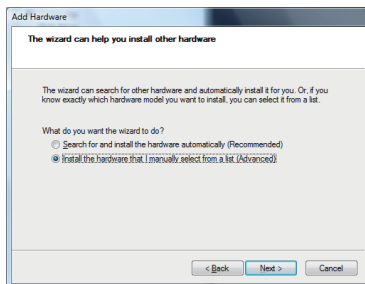

To the next page

3. Click the **Next >** button.

4. Select "Install the hardware that I manually select from a list (Advanced)" and click the **Next >** button.

5. Select "Network adapters" and click the **Next >** button.

6. Click the **Have Disk...** button.

7. Click the **Browse...** button.

From the previous page

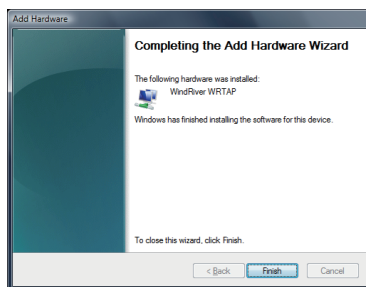
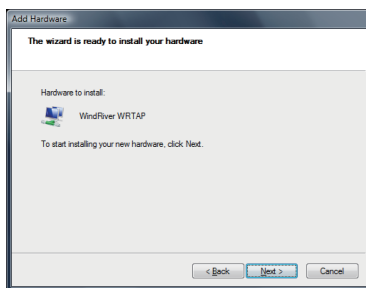
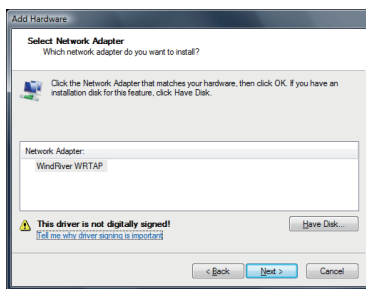
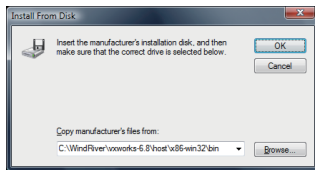
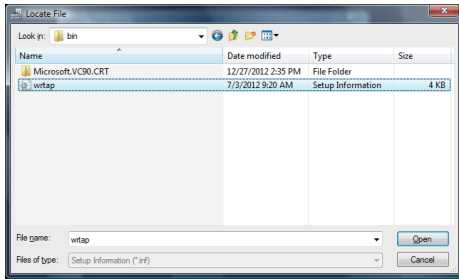

Completed

8. Select "wrtap.inf" and click the  button.

For details of the "wrtap.inf" folder, refer to the following remark.

 Page 43, Remark in this section

9. Click the  button.

10. Select "WindRiver WRTAP" and click the  button.

11. Click the  button.

If the following message box appears, click "Install this driver software anyway".

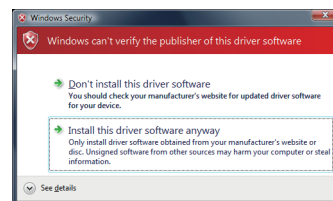

12. Click the  button.

### (3) Setting TCP/IP

1. Select [Start] ⇒ [Control Panel] ⇒ [Network and Internet] ⇒ [View network status and tasks], and click "Manage network connections".

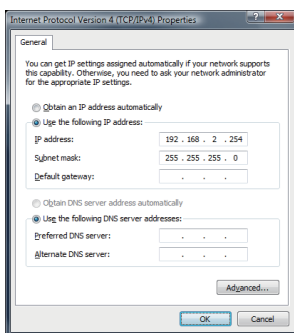
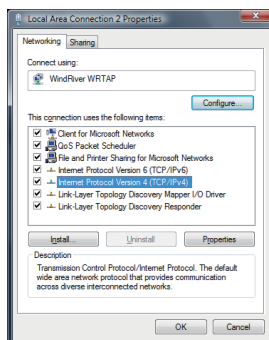
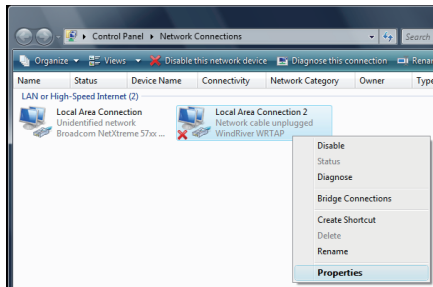

Completed

2. Click the local area connection with device name "WindRiver WRTAP". In the menu that pops up, select [Properties].

3. Select "Internet Protocol Version 4 (TCP/IPv4)" and click the  button.

4. Select "Use the following IP address:" and set "IP address" and "Subnet mask".

**Example** In this example, the following virtual network information is used.



IP address: 192.168.2.254

Subnet mask: 255.255.255.0

5. Click the  button.

# 10.3 Windows® XP

## (1) Setting Routing and Remote Access service

1. Select [Start] ⇒ [Control Panel] ⇒ [Administrative Tools] ⇒ [Service], and double-click "Routing and Remote Access".
2. Select "Automatic" for "Startup type" and click the  button.
3. Click the  button.
4. When the "Service status" becomes "Start", click the  button.

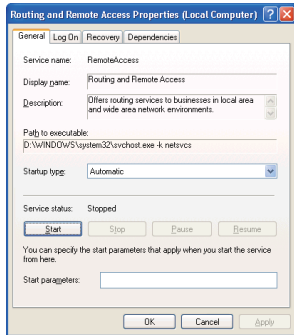

↓  
Completed

## (2) Setting network driver

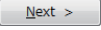
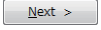
1. Select [Start] ⇒ [Control Panel] ⇒ [Add Hardware].
2. Click the  button.
3. Select "Yes, I have already connected the hardware" and click the  button.

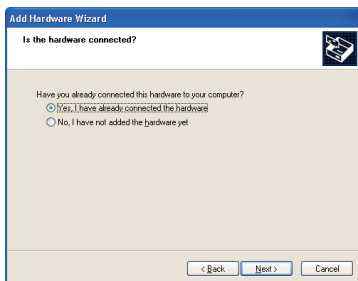

To the next page

From the previous page

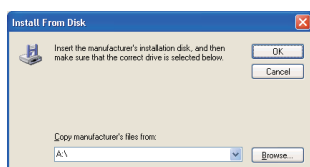
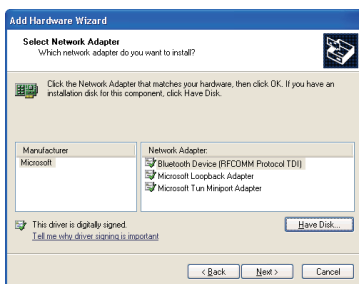
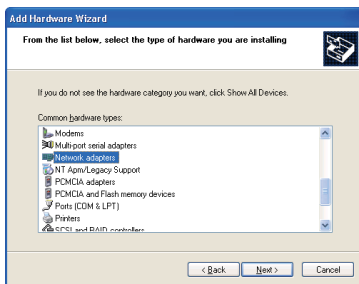
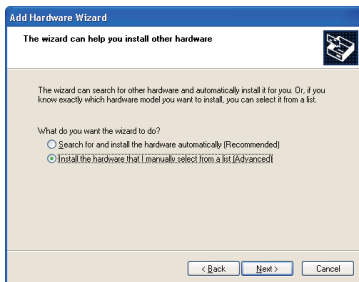
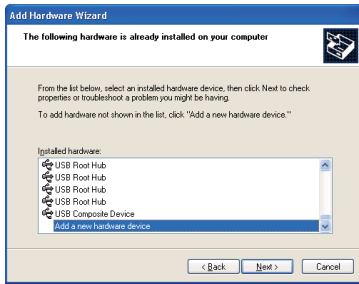

To the next page

4. Select "Add a new hardware device" and click the

button.

5. Select "Install the hardware that I manually select

from a list (Advanced)" and click the  button.

6. Select "Network adapters" and click the

button.

7. Click the  button.

8. Click the  button.

From the previous page

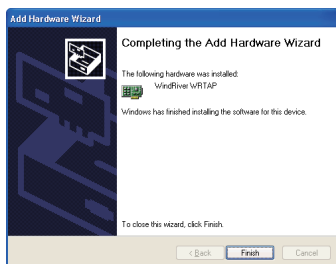
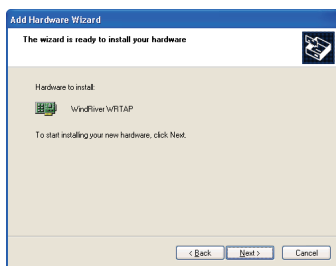
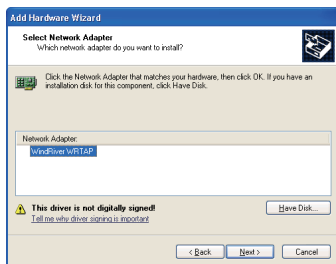
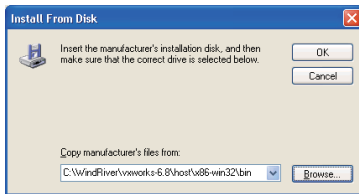
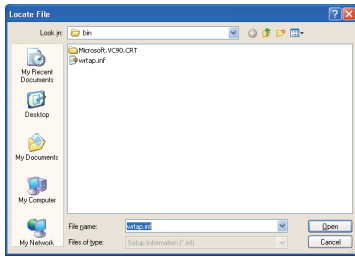

Completed

9. Select "wrtap.inf" and click the  button.

For details of the "wrtap.inf" folder, refer to the following remark.

 Page 43, Remark in this section

10. Click the  button.

11. Select "WindRiver WRTAP" and click the  button.

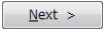
12. Click the  button.

If the following message box appears, click the

 button.



13. Click the  button.

### (3) Setting TCP/IP

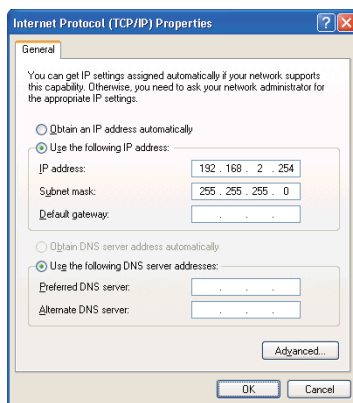
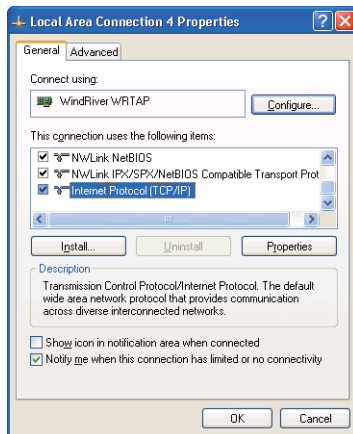
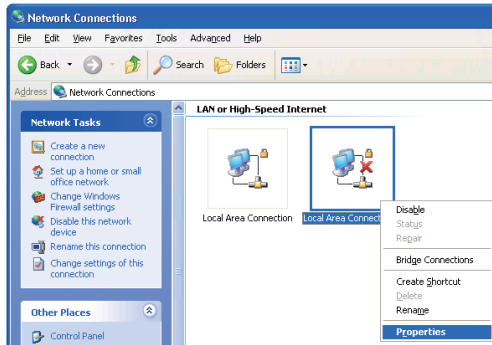

Completed

1. Select [Start] ⇒ [Control Panel] ⇒ [Network Connections].
2. Click the local area connection with device name "WindRiver WRTAP". In the menu that pops up, select [Properties].

3. Select "Internet Protocol (TCP/IP)" and click the  button.

4. Select "Use the following IP address:" and set "IP address" and "Subnet mask".

**Example** In this example, the following virtual network information is used.

IP address: 192.168.2.254

Subnet mask: 255.255.255.0

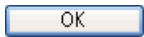
5. Click the  button.

# CHAPTER 11 CREATING AND BUILDING PROJECT

## 11.1 Creating Project

### 11.1.1 Creating new project

#### (1) How to create a new project

1. Select [Start] ⇒ [All Programs] ⇒ [Wind River] ⇒ [CW Workbench].
2. Enter a folder of storage location of workspace for "Workspace:".

Example "C:\CCPUSIM\" has been entered here as an example.

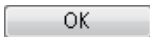
Clicking the  button starts CW Workbench.

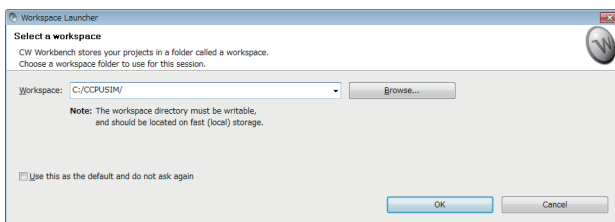

#### Remark

A message box shown below may appear. Click the  button.

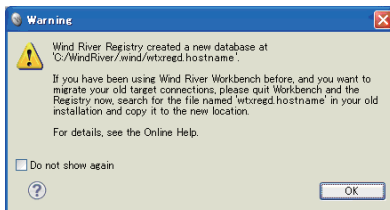

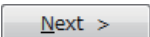
3. Select from the menu bar [File] ⇒ [New] ⇒ [Project...].
4. Select "VxWorks Downloadable Kernel Module Project" under "VxWorks 6.x" and click the  button.

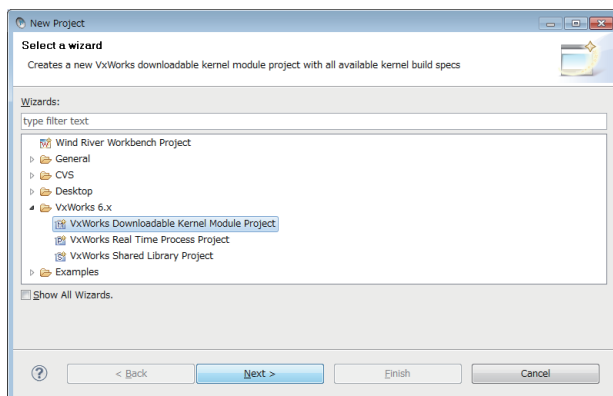



↓  
To the next page  
From the previous page

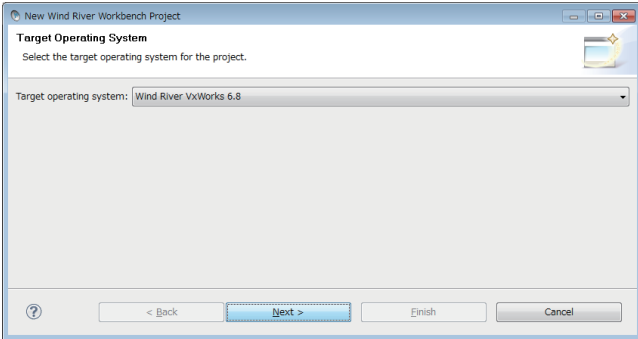

5. Select the following item for "Target operating system:". Click the **Next >** button.

- For Q24DHCCPU-V  
⇒ Wind River VxWorks 6.8
- For Q12DCCPU-V  
⇒ Wind River VxWorks 6.4

If there is no need to configure settings, this screen may not appear.

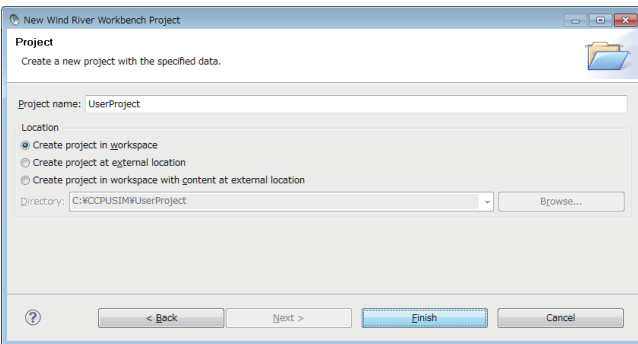

6. Enter a project name for "Project name:" and click the **Finish** button.

**Example** "UserProject" has been entered here as an example.

**Point!**

If characters that cannot be used or a project name that is already used are entered for "Project name:", an error text appears on the header of the window and the **Finish** button becomes disabled.

**Example** a space is included

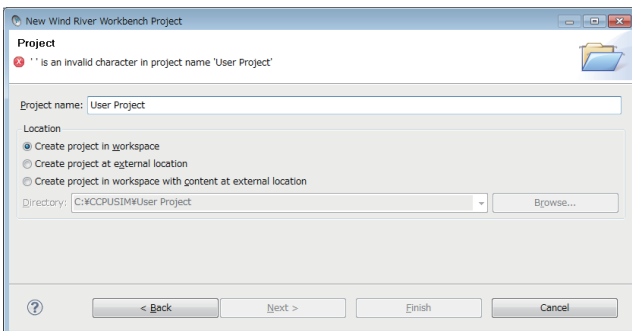

**Example** a project name that is already used is entered

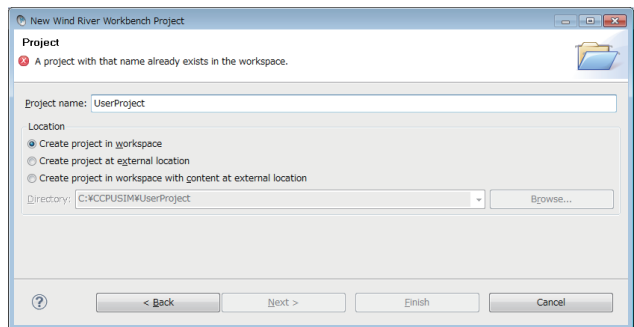

In addition, a space entered at the end of the project name is dropped.

**Example** "UserProject " ⇒ "UserProject"



A project created

## (2) How to set project properties for CW-Sim and CW-Sim Standalone

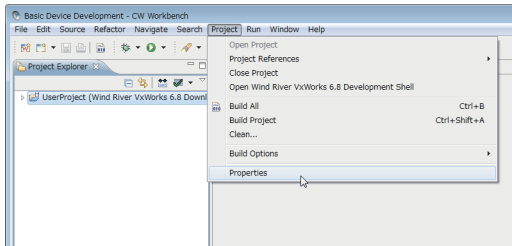

1. On the "Project Explorer" window, select a project where properties should be set. With the project selected, select from the menu bar [Project] ⇒ [Properties].

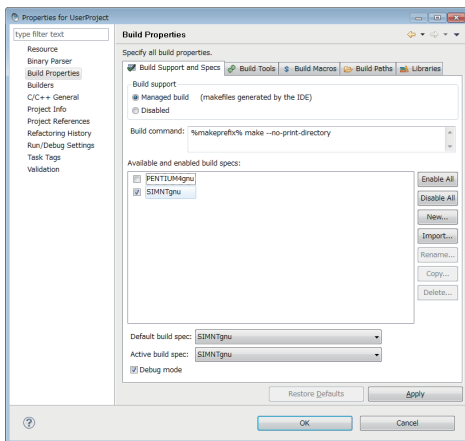

2. Select [Build Properties] from the tree view to the left on the window, and click the <<Build Support and Specs>> tab.

Check that only "SIMNTgnu" has been selected for "Available and enable build specs:".

If "SIMNTgnu" is not displayed, select [File] ⇒ [Switch Workspace] ⇒ [Other...], and switch to a new workspace to create a project.

### Point

- When the project has been imported, options other than "SIMNTgnu" may be displayed for "Available and enable build specs:". Since CW-Sim and CW-Sim Standalone support only "SIMNTgnu", clear any other check boxes.

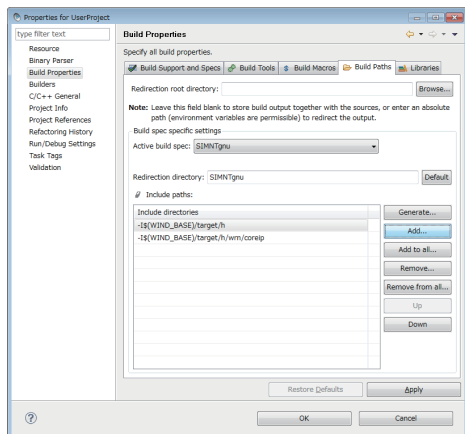

3. Select "Build Properties" from the tree on the left of the window.

Open the <<Build Paths>> tab and click the

**Add...** button.

To the next page

From the previous page

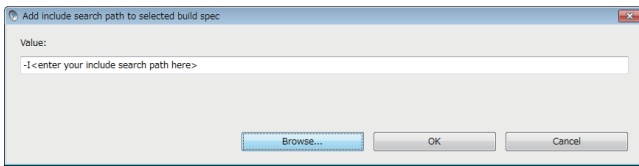

4. Click the **Browse...** button.

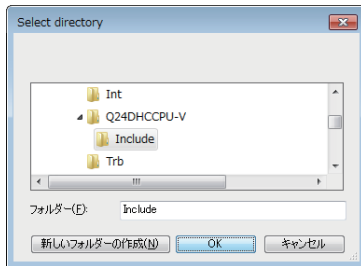

5. Select the include folder on the "Select directory" window.

Click the **OK** button.

### Remark

- The following are the paths for the include folder.
  - When SW4PVC-CCPU compatible with Q24DHCCPU-V is installed in "C:\MELSEC"
    - "C:\MELSEC\CCPU4\Q24DHCCPU-V\Include"
  - When SW3PVC-CCPU compatible with Q12DCCPU-V is installed in "C:\MELSEC"
    - "C:\Melsec\CCPU\DVx\Include"

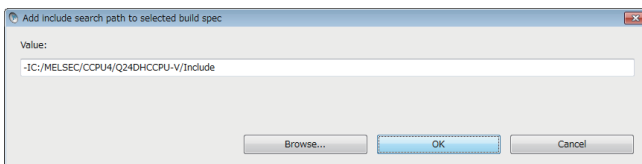

6. Check that the folder specified on the "Select directory" window has been selected.

Click the **OK** button.



To the next page

From the previous page

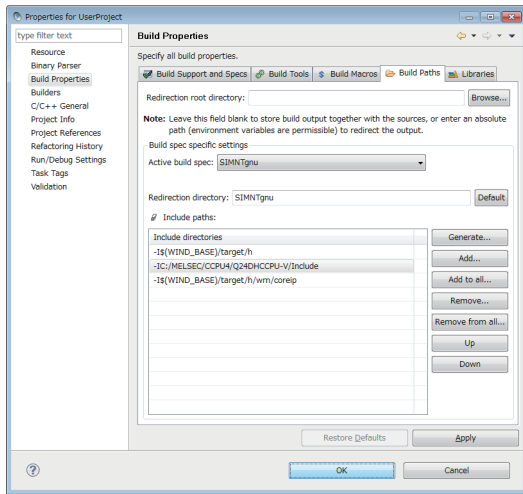

7. Check that the include path of MELSEC added to "Include directories" in "Include paths:" appears. Click the  button.

## Point

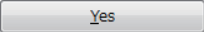
Click the  button. If the following message box appears, click the  button.

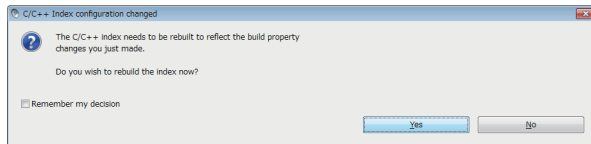

Properties setting completed

### (3) How to add a file to a project

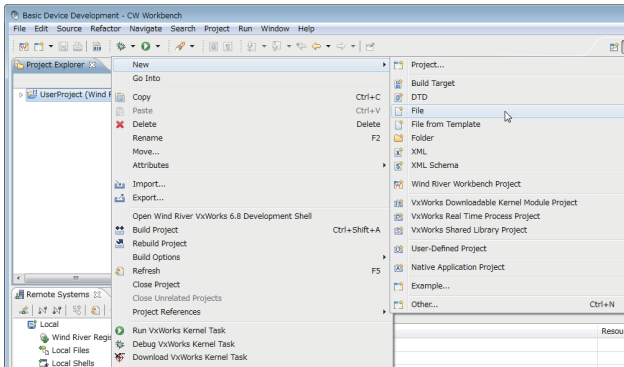

1. On the "Project Explorer" window, right-click a project where a file is added. Select from the pop-up menu [New] ⇒ [File].

#### Point

Various files can be added to the project using the new file addition function ([File] ⇒ [New] ⇒ [File] on the menu bar) or the project pop-up menu [Refresh]. However, note the following before adding files to the project:

- Do not add projects with the same name as the project name.
- If a file with the same name as the project name exists in the project, change the file name on Explorer and execute the project pop-up menu [Refresh].
  - Do not use the "Rename" function of CW Workbench to rename the file.
  - If the "Rename" function of CW Workbench is used to rename the file, an build error occurs and the project must be created again.

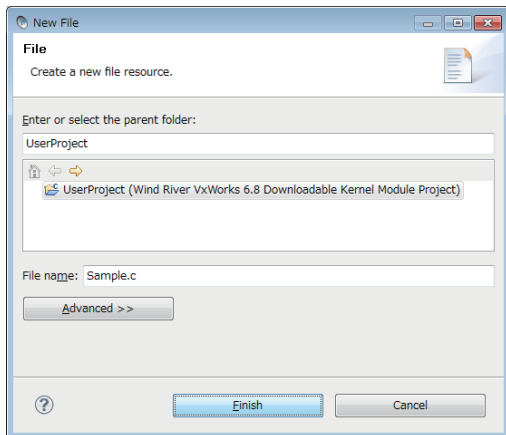

2. Enter a file name of a source file for "File name:". Click the **Finish** button.

Example "Sample.c" has been entered here as an example.



To the next page

From the previous page



## Point

- Enter a file name with extension (.c, .h, .cpp, .hpp) for "File name:"
- Do not use two-byte characters for a file name. Do not execute the compile for a file that has a name including two-byte characters, or a compile error occurs.
- If characters that cannot be used or a project name that is already used are entered for "File name:", an error text appears on the header of the window and the **Finish** button becomes disabled.

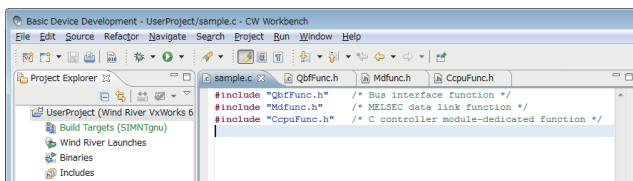
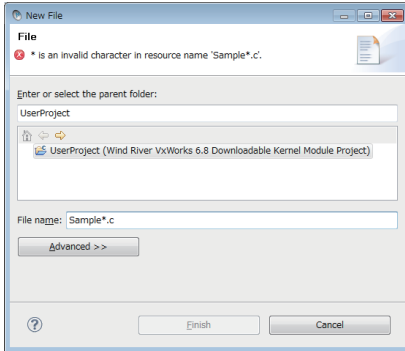

### 3. Edit the source files on the "Editor" window.

If the dedicated function library is used in the user program, include a header file of the dedicated function library.

#### [CAUTION]

The dedicated function library cannot be used with the simulator. To perform debugging on the simulator, create a stub for the dedicated function library or delete the caller.

A sample stub is included in the sample program stored on the CW-Sim CD-ROM (SW1DNC-CWSIM-ECD).

(☞ Page 16, Section 5.1 (2))

## Remark

- For Q24DHCCPU-V, include the following dedicated function libraries.
  - Bus interface function: "QbfFunc.h"
  - MELSEC data link function: "Mdfunc.h"
  - C controller module-dedicated function: "CcpuFunc.h"
- For Q12DCCPU-V, include the following dedicated function libraries.
  - Bus interface function: "QbfFunc.h"
  - MELSEC data link function: "Mdfunc.h"



A file added

### (4) How to import an existing project

For the procedure to import an existing project, refer to the following manual.

CW Workbench Operating Manual

## 11.1.2 Creating project using sample program

### (1) Sample program configuration

This section explains the sample programs provided on the CW-Sim CD-ROM (SW1DNC-CWSIM-ECD) and the system configuration when the sample program is executed.

- The system consists of 4 simulators, each of which is connected to the virtual network.
- On each simulator, the bus interface functions in the dedicated function library stub (QBF\_Simulator) and user programs using socket communication are running.

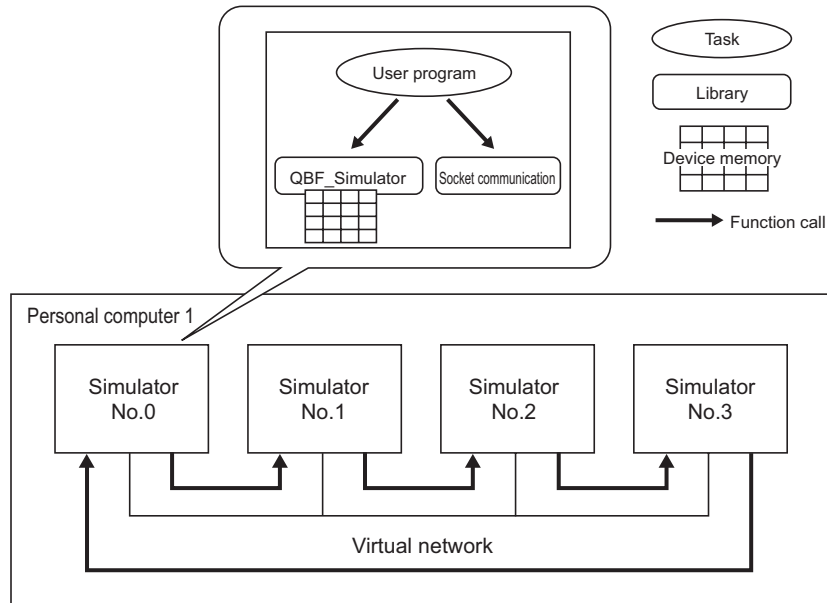

For QBF\_Simulator, the following device memory is simulated.

gpsDevArea

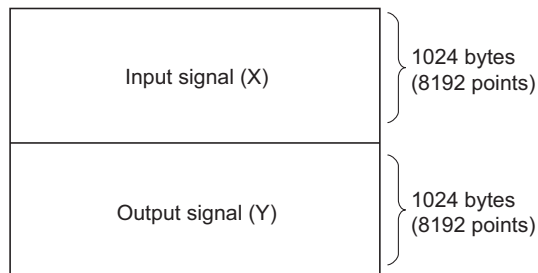

## (2) Sample program operations

### (a) Sample program operations (simulator No.0)

1. Establish the TCP/IP connections with the previous (No.3) and next (No.1) simulators.
2. Monitor X0 through X8192, and if X is turned ON, turn ON the Y data with the same device number.
3. Send the ON-detected device number of X in the step 2 to the next simulator (No.1) using the socket communication.
4. If the ON notification of X is received from the previous simulator (No.3), inversely output the Y data with the device number as same as the ON-notified device number of X.
5. Read the X data with the ON-notified device number and transfer the same data to the next simulator (No.1) if the status is ON.
6. Repeat the steps 1 through 5.

These operations turn the Y devices ON and OFF repeatedly.

### (b) Sample program operations (simulators No.1 through No.3)

1. Establish the TCP/IP connections with the previous and next simulators.
2. If the ON notification of X is received from the previous simulator, inversely output the Y data with the ON-notified device number plus 1 for the simulator No.1, Y data with the ON-notified device number plus 2 for the simulator No.2, and Y data with the ON-notified device number plus 3 for the simulator No.3.
3. Transfer the ON notification received in the step 2 to the next simulator.
4. Repeat the steps 2 and 3.

These operations turn the Y devices ON and OFF repeatedly.

## (3) Sample program preparation

Copy the sample program (☞ Page 16, Section 5.1 (2)) stored on the CW-Sim CD-ROM (SW1DNC-CWSIM-ECD) to a local folder.

**Example** Source folder and destination folder examples

- Source folder: <CD-ROM drive>:\Samples\English\simulation (all folders and files)
- Destination folder: C:\CCPUSIM



#### (4) Opening a sample program

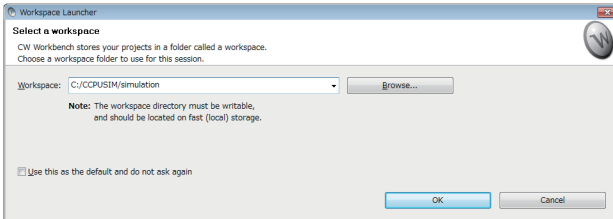

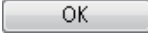
1. Select [Start] ⇒ [All Programs] ⇒ [Wind River] ⇒ [CW Workbench].
2. Specify the folder to which the sample program was copied for "Workspace:". (A folder can be also selected from the tree view by clicking the  button.)  
Clicking the  button starts CW Workbench.

Example "C:\CCPUSIM\simulation" has been entered here as an example.

**Remark**

The sample program is for VxWorks 6.8 (Q24DHCCPU-V). To open it in CW Workbench for VxWorks 6.4 (Q12DCCPU-V), convert it for VxWorks 6.4 (Q12DCCPU-V) by following the displayed messages.

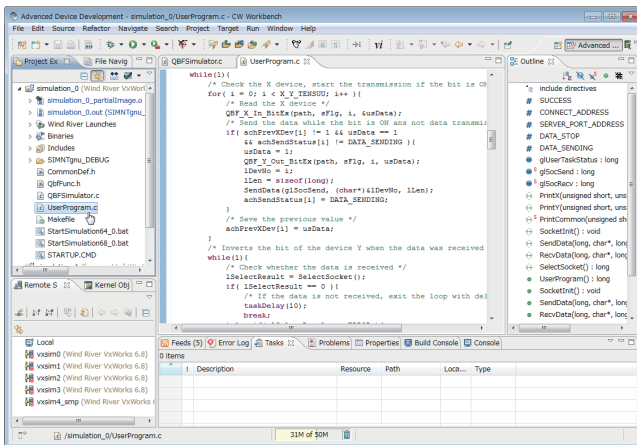

3. Double-clicking the sample program "UserProgram.c" in the "Project Explorer" window allows you to view/edit the sample program.

In this sample program, the stub for some bus interface functions is defined in "QbfFunc.h". Add a stub as necessary.



Completed

# 11.2 Building Project

## 11.2.1 How to build new project

For the procedure to build a new project, refer to the following manual.  
 ICW Workbench Operating Manual

## 11.2.2 Building project using sample program

The following is the procedure to build a project using the sample program.

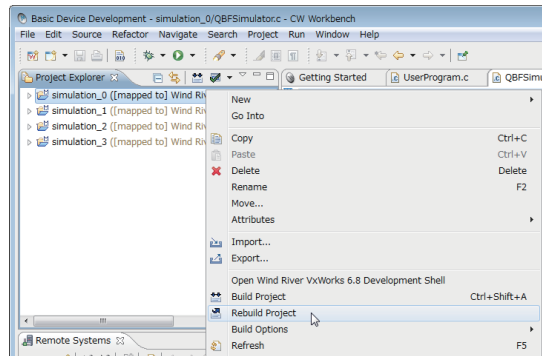
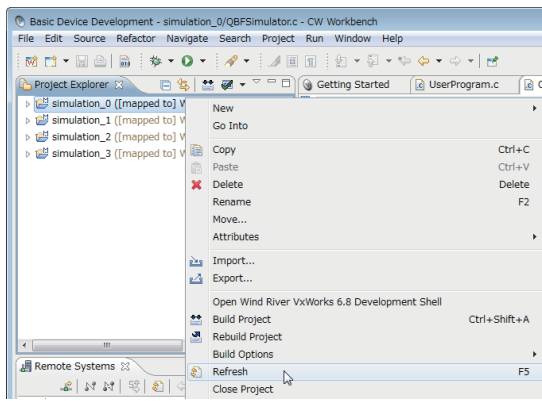

Build completed

1. On the "Project Explorer" window, right-click on a project name to be built. In the menu that pops up, select [Refresh].

This sample program contains the following 4 projects:

- simulation\_0
- simulation\_1
- simulation\_2
- simulation\_3

Perform [Refresh] for all projects.

2. On the "Project Explorer" window, right-click on a project name to be built. In the menu that pops up, select [Rebuild Project].

This sample program contains the following 4 projects:

- simulation\_0
- simulation\_1
- simulation\_2
- simulation\_3

Perform [Rebuild Project] for all projects.

### Point

For details of errors displayed after building the project and execution files to be generated, refer to the following manual.  
 ICW Workbench Operating Manual

# CHAPTER 12 PROGRAM DEBUGGING WITH CW-Sim

## 12.1 VxWorks Network Daemon Startup

This section explains the procedure to startup the VxWorks network daemon after CW Workbench and CW-Sim are installed to "C:\WindRiver".

### (1) Create a VxWorks network configuration file.

**Example** A text file "vxsimnetd.conf" is created in "C:\CCPUSIM" here as an example.

**Example** Contents of "vxsimnetd.conf" are as follows:

```
SUBNET_START sub2 {
    SUBNET_ADDRESS = "192.168.2.0";
    SUBNET_EXTERNAL = yes;
    SUBNET_EXTPROMISC = yes;
};
```

### Point

- Modify the contents of "vxsimnetd.conf" as necessary by referring the following.
  - 📖 WindRiver VxWorks Simulator User's Guide
- A sample of "vxsimnetd.conf" is stored in the folder "\samples\English" on the CW-Sim CD-ROM (SW1DNC-CWSIM-ECD).

### (2) Startup the VxWorks network daemon.

Select [Start] ⇒ [All Programs] ⇒ [Accessory] ⇒ [Command Prompt].

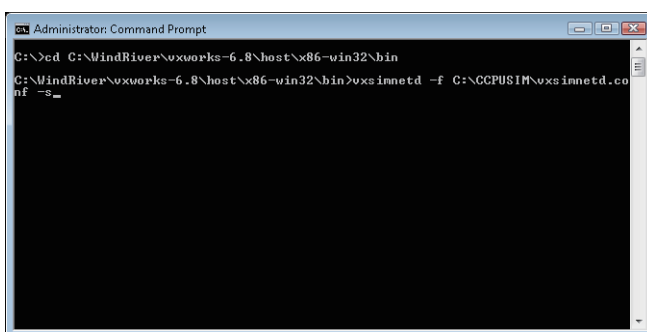

```
Administrator: Command Prompt
C:\>cd C:\WindRiver\vxworks-6.8\host\x86-win32\bin
C:\WindRiver\vxworks-6.8\host\x86-win32\bin>vxsimnetd -f C:\CCPUSIM\vxsimnetd.conf -s
```

#### 1. To change the current directory to the installation folder of CW-Sim, enter the following command.

- For Q24DHCCPU-V
  - "cd C:\WindRiver\vxworks-6.8\host\x86-win32\bin"
- For Q12DCCPU-V
  - "cd C:\WindRiver\vxworks-6.4\host\x86-win32\bin"

#### 2. To startup the VxWorks network daemon, enter the following command.

→ "vxsimnetd -f C:\CCPUSIM\vxsimnetd.conf -s"

### Point

- Startup the VxWorks network daemon only once after the personal computer startup.
- Do not close the above command prompt during debugging. Otherwise, the network daemon closes.

# 12.2 Simulator Startup

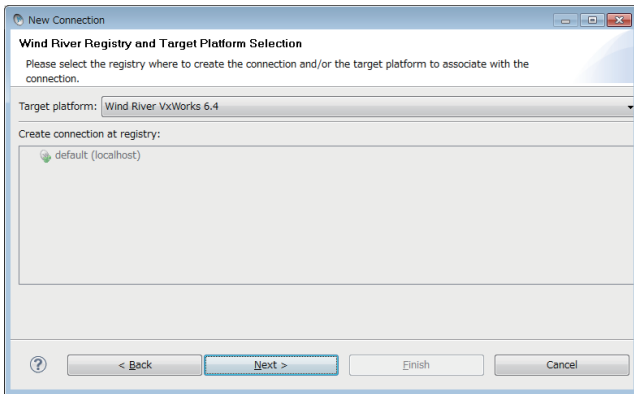
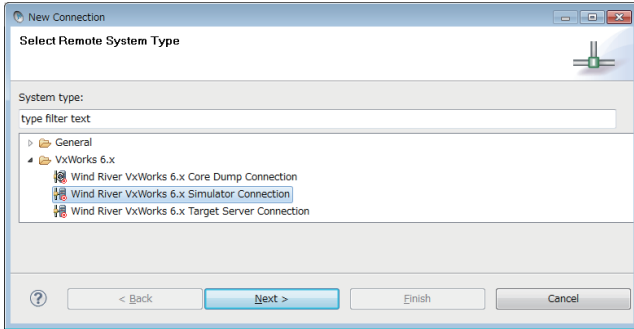
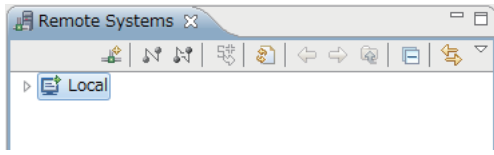

To the next page

1. Click the "Define a connection to remote system" button  on the "Remote Systems" window.

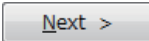
2. Select the "Wind River VxWorks 6.x Simulator Connection" under "VxWorks 6.x" and click the  button.

3. Select the following item for "Target platform" and click the  button.

- For Q24DHCCPU-V:  
→ "Wind River VxWorks 6.8"
- For Q12DCCPU-V:  
→ "Wind River VxWorks 6.4"

If there is no need to configure settings, this screen may not appear.

From the previous page

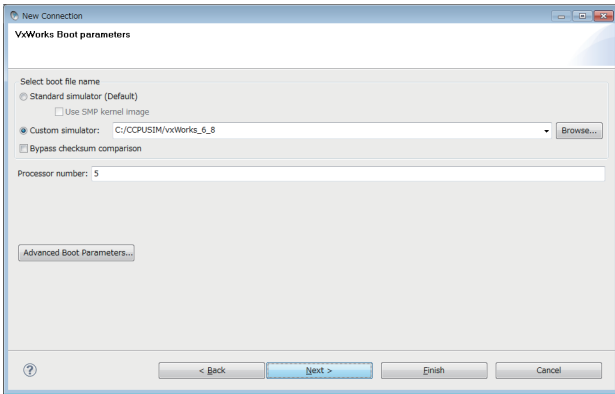

4. Select "Custom simulator" under "Select boot file name" and enter the path to the VxWorks image file and file name.

**Example** The destination of the VxWorks image file is set to "C:\CCPUSIM" here as an example. (← Page 34, Section 8.1.3)

5. Click the **Next >** button.

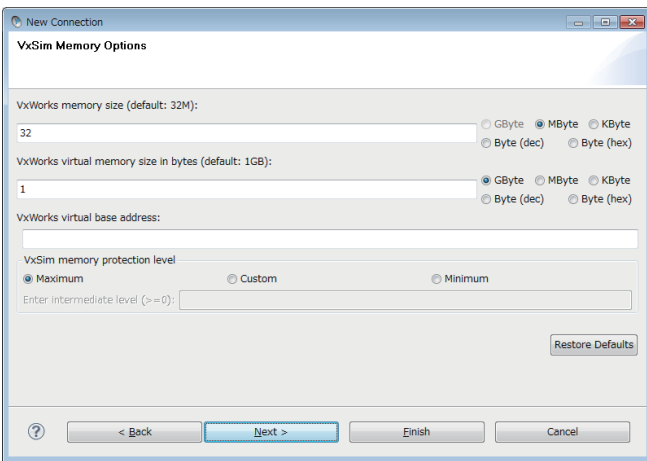

6. Click the **Next >** button.

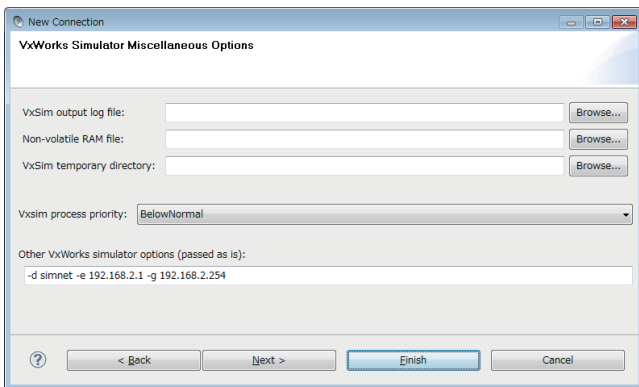

7. Set the IP address and default gateway of the virtual network for "Other VxWorks simulator options".

**Example** The following virtual network information is used here as an example.

- IP address: "192.168.2.1"
- Default gateway: "192.168.2.254"

Settings in this case should be as follows:  
→ "-d simnet -e 192.168.2.1 -g 192.168.2.254"

8. Click the **Finish** button.



To the next page



# 12.3 Debugging Program

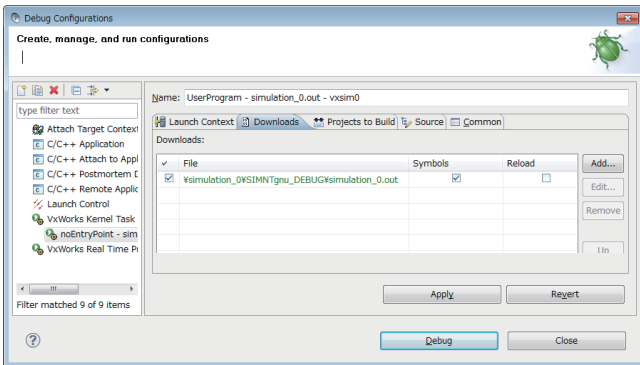
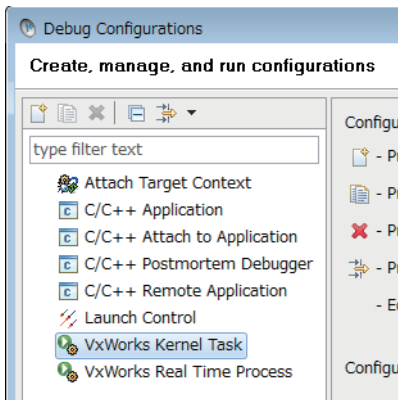
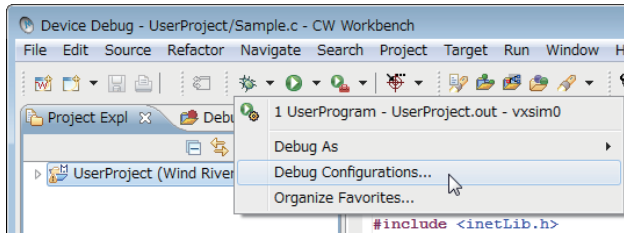

To the next page

1. On the "Project Explorer" window, select a project to debug and click "▼" at the right of the debug icon (  ).
2. In the menu that pops up, select [Debug Configurations...].
3. Double-click "VxWorks Kernel Task"

This operation creates a new debug configuration.

4. Click the <<Downloads>> tab and check the .out file to be downloaded.

If the .out file of the project selected in the step 1 is not registered, click the  button to register it.

From the previous page

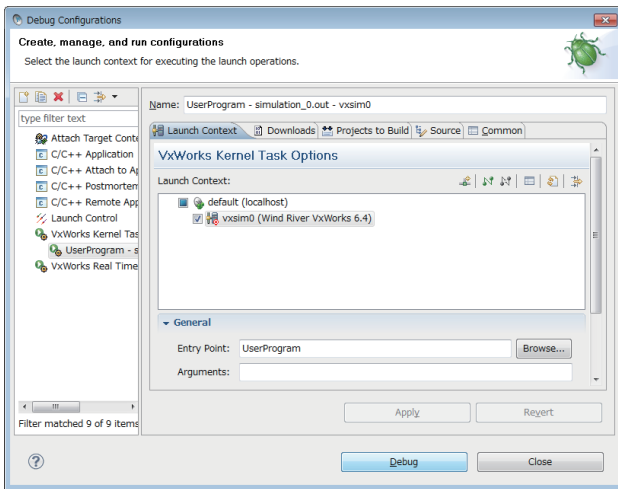

Debugging started

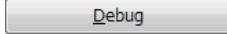
5. Click the <<Launch Context>> tab and select the connection target set in the step 9 on Page 68.
6. Specify the function to start debugging for "Entry Point" and click the  button.

---

### Point!

For the operations after starting the debugging, refer to the following manual.

 CW Workbench Operating Manual

---



# CHAPTER 13 EXECUTION OF SAMPLE PROGRAM WITH CW-Sim

## 13.1 VxWorks Network Daemon Startup

For the procedure to startup the VxWorks network daemon, refer to the following section.

☞ Page 65, Section 12.1

## 13.2 Creating Simulator

The sample program uses 4 simulators vxsim0 to vxsim3.

Perform the following operations 4 times to create simulators vxsim0 to vxsim3.

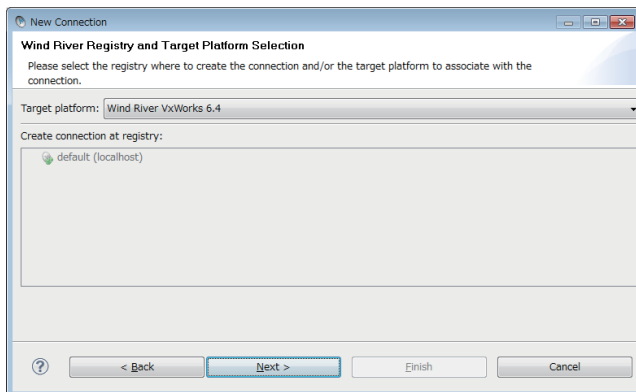
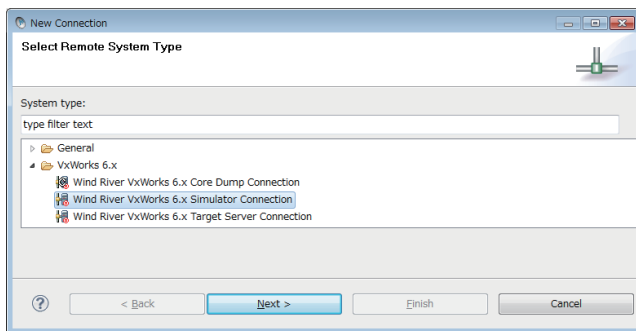
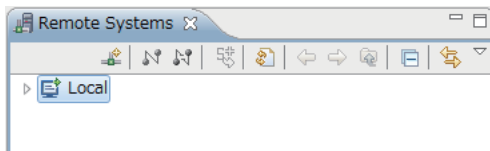

To the next page

1. Click the "Define a connection to remote system" button  on the "Remote Systems" window.

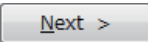
2. Select "Wind River VxWorks 6.x Simulator Connection" under "VxWorks 6.x" and click the  button.

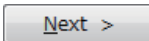
3. Select the following item for "Target platform" and click the  button.

- For Q24DHCCPU-V:  
→ "Wind River VxWorks 6.8"
- For Q12DCCPU-V:  
→ "Wind River VxWorks 6.4"

If there is no need to configure settings, this screen may not appear.

From the previous page

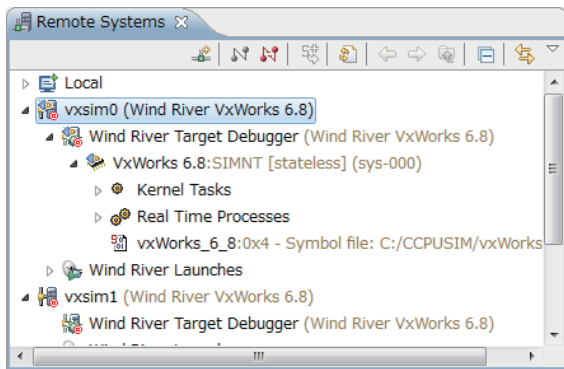
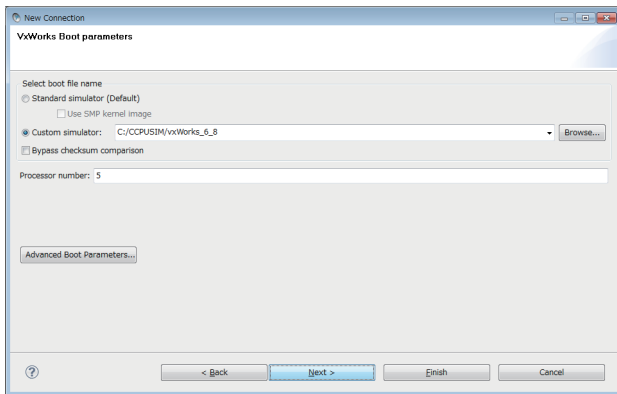

A simulator created

4. Select "Custom simulator" under "Select boot file name" and enter the path to the VxWorks image file and file name.

**Example** The destination of the VxWorks image file is set to "C:\CCPUSIM" here as an example.  
( Page 34, Section 8.1.3)

5. Click the button.

6. When the connection to the simulator is established, the "Target Console" screen appears.

7. Click the "Disconnect" button on the "Remote Systems" window and close the "Target Console" screen.

## 13.3 Simulator Settings

Perform the following operations 4 times to configure the settings for simulators vxsim0 to vxsim3.

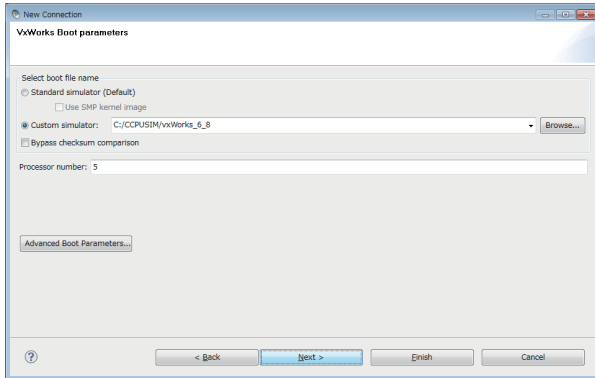

1. On the "Remote Systems" window, right-click on the simulator (vxsim0 to vxsim3). In the menu that pops up, select [Properties].
2. On the <<Miscellaneous Options>> tab, specify the storage folder of the "STARTUP.CMD" file for "VxSim temporary directory".

**Example** The storage location of the sample program is set to "C:\CCPUSIM\simulation" here as an example.

(☞ Page 62, Section 11.1.2 (3))

- For vxsim0  
→ "C:\CCPUSIM\simulation\simulation\_0"
- For vxsim1  
→ "C:\CCPUSIM\simulation\simulation\_1"
- For vxsim2  
→ "C:\CCPUSIM\simulation\simulation\_2"
- For vxsim3  
→ "C:\CCPUSIM\simulation\simulation\_3"

[CAUTION] For the project to be debugged, leave the above settings blank.

3. Set the IP address and default gateway of the virtual network for "Other VxWorks simulator options".

The following examples are the settings of "Other VxWorks simulator options" with the default gateway set to "192.168.2.254".

**Example** IP address of vxsim0 (No.0): "192.168.2.1" → "-d simnet -e 192.168.2.1 -g 192.168.2.254"

**Example** IP address of vxsim1 (No.1): "192.168.2.2" → "-d simnet -e 192.168.2.2 -g 192.168.2.254"

**Example** IP address of vxsim2 (No.2): "192.168.2.3" → "-d simnet -e 192.168.2.3 -g 192.168.2.254"

**Example** IP address of vxsim3 (No.3): "192.168.2.4" → "-d simnet -e 192.168.2.4 -g 192.168.2.254"

### Point

To change the IP address settings, change the IP address definitions in the sample program and rebuild the project.

4. Click the  button.



CW-Sim setting completed

# 13.4 Execution of Sample Program

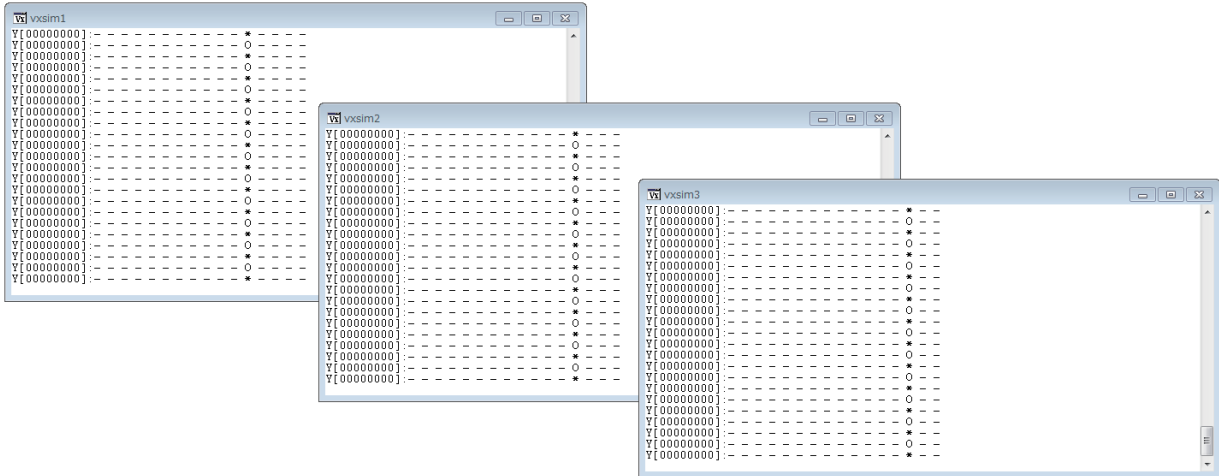
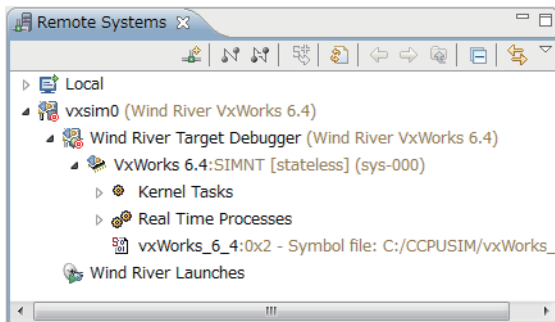
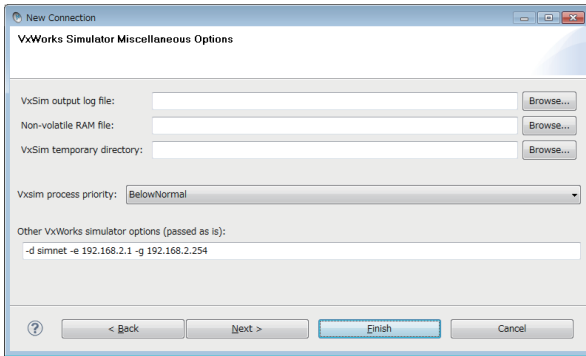

## Point

ON/OFF status of the Y devices is displayed on the "Target Console" screen of vxsim1 to vxsim3.

- "\*" = ON
- "0" = OFF
- "-" = Not displayed



Sample program executed

1. On the "Remote Systems" window, select the simulator (vxsim0 to vxsim3) and click the "Connect" button  to startup CW-Sim.

Startup CW-Sim in the following order:

- vxsim3 (No.3)
- vxsim2 (No.2)
- vxsim1 (No.1)
- vxsim0 (No.0)

2. Executing the X\_On() function on the "Target Console" screen of vxsim0 starts the operations of the sample program.

**Example** Entering "X\_On(10)" turns X10 ON, and ON/OFF of the Y devices starts.

**Remark**

For operations of the sample program, refer to the following figure.

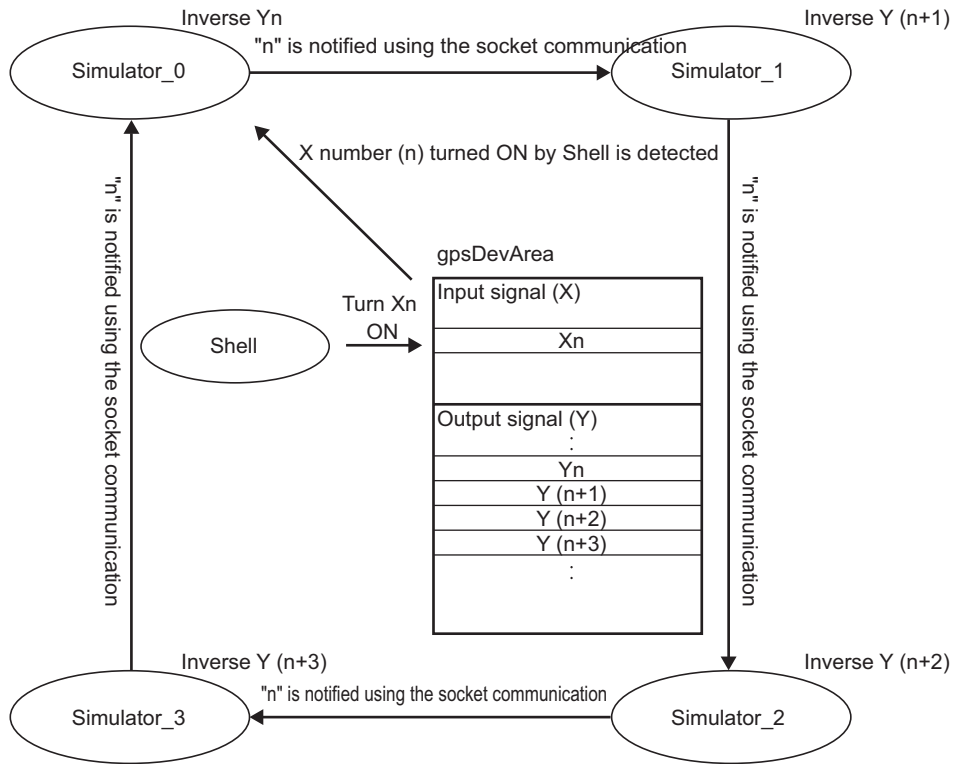

# CHAPTER 14 EXECUTION OF PROGRAM WITH CW-Sim Standalone

---

This chapter explains how to execute programs using CW-Sim Standalone.

## 14.1 VxWorks Network Daemon Startup

---

This section explains the procedure to startup the VxWorks network daemon when CW-Sim Standalone is installed under "C:\CCPUSIM".

### (1) Create a VxWorks network configuration file.

Refer to the following section.

☞ Page 65, Section 12.1 (1)

### (2) Startup the VxWorks network daemon.

Select [Start] ⇒ [All Programs] ⇒ [Accessory] ⇒ [Command Prompt].

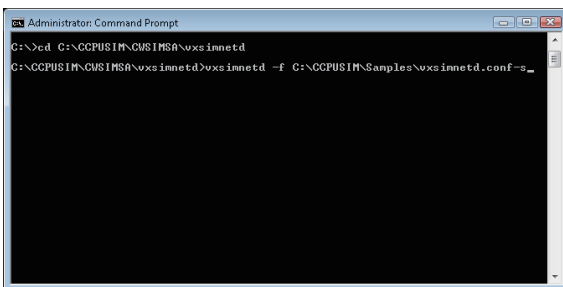

```
Administrator: Command Prompt
C:\>cd C:\CCPUSIM\CWSIMSA\vxsimnetd
C:\CCPUSIM\CWSIMSA\vxsimnetd>vxsimnetd -f C:\CCPUSIM\Samples\vxsimnetd.conf -s
```

1. To change the current directory to the installation folder of CW-Sim Standalone, enter the following command.  
→ "cd C:\CCPUSIM\CWSIMSA\vxsimnetd"
2. To startup the VxWorks network daemon, enter the following command.  
→ "vxsimnetd.exe -f C:\CCPUSIM\Samples\vxsimnetd.conf -s"

---

### Point

- Startup the VxWorks network daemon only once after the personal computer startup.
  - Do not close the above command prompt during simulation. Otherwise, the network daemon closes.
-

## 14.2 Simulator Startup

This section explains the procedure to startup the simulator from the command prompt.

**Example** In this example, the following virtual network information is used.

- IP address: "192.168.2.1"
- Default gateway: "192.168.2.254"

**1. To change the current directory to the installation folder of CW-Sim Standalone, enter the following command.**

- For Q24DHCCPU-V:  
→ "cd C:\CCPUSIM\CWSIMSA\vxsim68"
- For Q12DCCPU-V:  
→ "cd C:\CCPUSIM\CWSIMSA\vxsim64"

**2. To startup the simulator, enter the following command.**

- For Q24DHCCPU-V:  
→ "vxsim68-nl.exe -f C:\CCPUSIM\vxWorks\_6\_8 -d simnet -e 192.168.2.1 -g 192.168.2.254"
- For Q12DCCPU-V:  
→ "vxsim64-nl.exe -f C:\CCPUSIM\vxWorks\_6\_4 -d simnet -e 192.168.2.1 -g 192.168.2.254"

```
Administrator: Command Prompt
C:\>cd C:\CCPUSIM\CWSIMSA\vxsim68
C:\CCPUSIM\CWSIMSA\vxsim68>vxsim68-nl.exe -f C:\CCPUSIM\vxWorks_6_8 -d simnet -e 192.168.2.1 -g 192.168.2.254
C:\CCPUSIM\CWSIMSA\vxsim68>
```

### Point

- To startup multiple simulators  
Specify a processor number in the "-p" option.
- If ""STARTUP.CMD" file dose not exit" is displayed at the simulator startup and the script is not executed, change the current directory to the folder containing the script file "STARTUP.CMD" and enter the following command.
  - For Q24DHCCPU-V:  
→ "C:\CCPUSIM\CWSIMSA\vxsim68\vxsim68-nl.exe -f C:\CCPUSIM\vxWorks\_6\_8 -d simnet -e 192.168.2.1 -g 192.168.2.254"
  - For Q12DCCPU-V:  
→ "C:\CCPUSIM\CWSIMSA\vxsim64\vxsim64-nl.exe -f C:\CCPUSIM\vxWorks\_6\_4 -d simnet -e 192.168.2.1 -g 192.168.2.254"
- For argument of each command, refer to the following manual.
  - For Q24DHCCPU-V:  
📖 Wind River VxWorks Simulator User's Guide, 6.8
  - For Q12DCCPU-V:  
📖 Wind River VxWorks Simulator User's Guide, 6.1





# CHAPTER 15 TROUBLESHOOTING

The following table lists errors that occur during use of CW-Sim and their solutions.

Category	Problem	Reference
Installation	The CW-Sim installer has stopped working half way through. Or the installer has terminated suddenly during installation.	CW Workbench Operating Manual
	When selecting a license file, the message "Your Product Activation File does not have a valid install key for any Products on Disk. Please re-enter a new Product Activation File." appears and installation fails.	Page 80, Section 15.1 (1)
	After installation, an error is output in "setup.log" and the simulator does not operate normally.	Page 81, Section 15.1 (2)
Installation using a temporary license	After an LAC code and user information are entered and the <input type="button" value="Next &gt;"/> button is clicked, an error message appears and the installation does not progress.	Page 82, Section 15.2 (1)
License	You have received a permanent license file, but do not know how to use it.	Page 83, Section 15.3 (1)
	You do not know how to delete a permanent license file.	Page 83, Section 15.3 (2)
	The message "Checking License...ERROR" appears and the simulator does not start.	Page 83, Section 15.3 (3)
CW Workbench startup	The message "The install root of your Wind River Workbench installation could not be located!" appears and CW Workbench does not start.	CW Workbench Operating Manual
	The message "Workspace in use or cannot be created, choose a different one." appears and CW Workbench does not start.	
	The displayed contents do not change after patch application.	
Simulator startup	The option "Wind River VxWorks 6.x Simulator Connection" is not included in the "Define a connection to remote system" settings.	Page 84, Section 15.4 (1)
	In VxWorks 6.4, the simulator system time varies from the actual time.	Page 84, Section 15.4 (2)
	At the startup of VxWorks network daemon, the warning "WARNING:subnet(***): external configuration failed (can't find a WRTAP network connection to use)." or the error "[SC] OpenSCManager FAILED 5: Access denied" appears and the virtual network is not enabled.	Page 85, Section 15.4 (3)
	Network communication with the simulator cannot be established.	Page 85, Section 15.4 (4)
Building	An error "command not found" has occurred and the build is not executed.	CW Workbench Operating Manual
	An error "no input files", "No Such file", or "No such file or directory" has occurred.	
	An error "Build target "/>	
	The following build errors have occurred: "xxx.sh: syntax error near unexpected token 'yyy_partialImage/Debug/Objects/nnn'" "xxx.sh: cannot execute binary file" "Makefile:xxx: *** missing separator. Stop" "No rule to make target ***, needed by `***`. Stop." "yy.o: command not found - No such file or directory"	
	.out file is not created.	
	The build terminates with a message "Generation of makefiles started."	

# 15.1 Installation

---

## (1) When selecting a license file, the message "Your Product Activation File does not have a valid install key for any Products on Disk. Please re-enter a new Product Activation File." appears and installation fails.

An error has occurred in license file checking during CW-Sim installation.

Possible causes and recovery methods of the license error are described below.

### (a) Not a license file of CW-Sim

A license file of a different product such as CW Workbench may be used.

- Recovery method  
Check the license file and apply the license file for CW-Sim.

### (b) CW-Sim is already installed

- Recovery method  
Uninstall CW Workbench and CW-Sim to delete the license file and then reinstall CW Workbench and CW-Sim.

### (c) Invalid license is used

If the host information registered in acquisition of permanent license is incorrect, a license error occurs.

### *Point*

---

- When "MAC" is used as host machine information for permanent license application  
Recheck the Host ID of the personal computer on which CW-Sim is used.
  - When "DISK" is used as host machine information for permanent license application  
An error occurs if any DISK serial number other than C drive is specified as Host ID.  
Specify the DISK serial number of the C drive as Host ID.  
If the personal computer is equipped with more than one drive, do not specify any DISK serial number other than that of the C drive as Host ID.
- 

- Recovery method in case of wrong Host ID  
Use "PermanentLicenseApplicationForm.xls" that can be found on the CD-ROM to transfer the host machine. Host ID to be entered is as follows.  
→ Enter the wrong Host ID registered previously for "Current license".  
→ Enter the correct Host ID to be registered for "New license".
- Recovery method in case of correct Host ID  
Please contact your local Mitsubishi service center or representative from whom you purchased CW-Sim.

## (2) After installation, an error is output in "setup.log" and the simulator does not operate normally.

CW Workbench may not be installed, or CW-Sim is installed in a folder other than the CW Workbench installation folder.

**Example** Excerpts from error messages output in "setup.log"

---

```
Error during execution of postinstall command: [Ljava.lang.String:@13a0067, : java.io.IOException: Cannot run
program "C:\WindRiver\setup\bspinstall.bat":CreateProcess error=3, The system cannot find the path specified
```

---

```
Error during execution of postinstall command: [Ljava.lang.String:@f0761a, : java.io.IOException: Cannot run program
"C:\WindRiver\setup\postinstall.bat":CreateProcess error=3, The system cannot find the path specified
```

---

```
Command C:\WindRiver\vxworks-6.4\setup\mit_vxsim_postinstall.bat terminated with exit status: 1. It issues the
following output on standard out: [], and the following output on standard err: [The system cannot find the path specified
```

---

```
Error during execution of postinstall command: [Ljava.lang.String:@127f4f9, : java.io.IOException: Cannot run program
"C:\WindRiver\vxworks-6.8\setup\vx_postinstall.bat": CreateProcess error=2, The system cannot find the path specified
```

---

Response action is described below.

### 1. Uninstall CW-Sim.

Perform uninstallation from "Product Maintenance".

Select [Start] ⇒ [All Programs] ⇒ [Wind River] ⇒ [Product Maintenance] ⇒ [Installation at X YYYY], and uninstall all items.

### Point

- X and YYYY of [Installation at X YYYY] mean:  
X: The drive to which the product has been installed  
YYYY: The folder to which the product has been installed

**Example**

If the folder of the installation location specified at the time of installation is C:\WindRiver, the menu name is [Installation at C WindRiver].

---

### 2. If CW Workbench is not installed, install CW Workbench.

### 3. Reinstall CW-Sim in the same folder as the CW Workbench installation folder.

## 15.2 Installation Using Temporary License

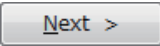
(1) After an LAC code and user information are entered and the  button is clicked, an error message appears and the installation does not progress.

- Error message

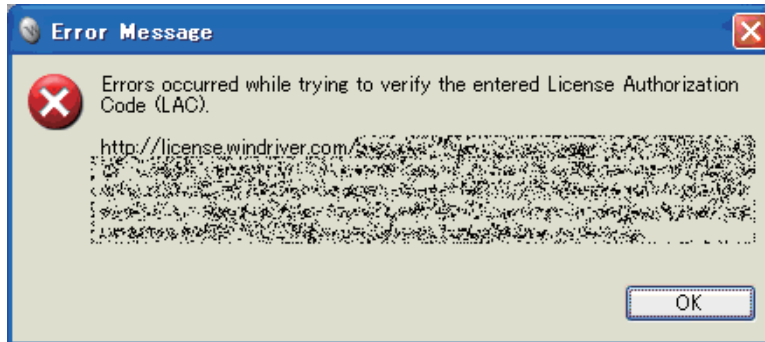

- Action

The following table describes how to respond to the error text displayed in the "Error Message" dialog box.

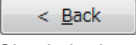
Error text	Action
HTTP Server: Bad Gateway	The HTTP server you are trying to access may not be responding properly. Try to install the product later. If the problem still remains, try to install the product another day.
Unknown Host:	The personal computer in use may be connected to the Internet via a proxy server. Use the  button and go back to the "Installer-Online Update Settings" window. Check the box of "Connect to internet using proxy server" and configure the proxy server setting.
Unable to read repository at	The personal computer in use may not be connected to the Internet. Check that the personal computer can be connected to the Internet.
Unable connect to repository	Install the product on the personal computer being connected to the Internet. When the personal computer is connected via a proxy server, conduct the measure of the error text (Unknown Host) above.

## 15.3 License

---

### (1) You have received a permanent license file, but do not know how to use it.

Store the obtained permanent license file in the license folder in the personal computer where CW Workbench has been installed.

☞ Page 23, Section 7.2

### (2) You do not know how to delete a permanent license file.

Delete all the files in the license folder in the personal computer where CW Workbench has been installed.

☞ Page 24, Section 7.3

### (3) The message "Checking License ...ERROR" appears and the simulator does not start.

An error has occurred in license file checking during CW-Sim startup.

Possible causes and recovery methods of the license error are described below.

#### (a) Expiration of trial period

If CW-Sim is used with a temporary license, the license error occurs after 31 days from installation of CW-Sim.

- Recovery method

Obtain the permanent license and overwrite the obtained license file to use CW-Sim.

#### (b) Invalid license is used

If the host information registered in acquisition of permanent license is incorrect, a license error occurs. For details, refer to the following section.

☞ Page 80, Section 15.1 (1)(c)

# 15.4 Simulator Startup

(1) The option "Wind River VxWorks 6.x Simulator Connection" is not included in the "Define a connection to remote system" settings.

Data before installation of CW-Sim may be left in CW Workbench cache.

Add "-clean" as an argument at the startup of CW Workbench to clear the cache.

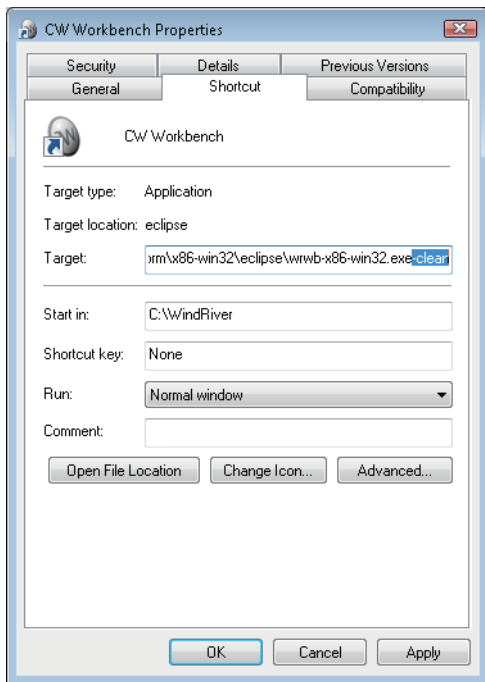

1. Right-click the CW Workbench shortcut on Desktop. In the menu that pops up, select [Properties].

2. Add a space at the end of "Target" in the CW Workbench property and then enter "-clean" after the space.

Click the  button.

3. Double-click the CW Workbench shortcut on the desktop and startup CW Workbench.

↓  
Cache cleared

### Point

It is not necessary to clear the cache every time.

After the cache is cleared, delete "-clean" added on the screen in the step 2.

(2) In VxWorks 6.4, the simulator system time varies from the actual time.

Correction of the clock rate setting may be needed depending on the personal computer operating environment.

(The default clock rate setting value is "60".)

Execute the sysClkRateSet() function on the "Target Console" screen to correct the time to the actual time.

**Example** To change the clock rate setting to "64"

"sysClkRateSet(64)"

**(3) At the startup of VxWorks network daemon, the warning "WARNING:subnet(\*\*\*) external configuration failed (can't find a WRTAP network connection to use)." or the error "[SC] OpenSCManager FAILED 5: Access denied" appears and the virtual network is not enabled.**

In the command prompt, commands must be executed with the administrative right.

To execute commands with the administrative right, launch the command prompt by following the procedure below.

1. Select [Start] ⇒ [All Programs] ⇒ [Accessory].
2. Right-click [Command Prompt]. In the menu that pops up, select [Run as administrator].

**(4) Network communication with the simulator cannot be established.**

If Windows® Firewall is enabled, "VxSim Network Daemon" must be registered to the firewall exception list.

For checking and setting procedures for the firewall exception list, refer to the following manual.

 Setting/Monitoring Tools for C Controller Module Operating Manual

**Point** 

To register "VxSim Network Daemon" to the exception list by following the setting procedure of the above manual, click the "Browse" button on the screen for adding programs and select "vxsimnetd.exe".

**Remark**

- If the installation folder of CW Workbench and CW-Sim is "C:\WindRiver", the folder for "vxsimnetd.exe" is set as follows:
  - For Q24DHCCPU-V
    - "C:\WindRiver\vxworks-6.8\host\x86-win32\bin"
  - For Q12DCCPU-V
    - "C:\WindRiver\vxworks-6.4\host\x86-win32\bin"
- For CW-Sim Standalone, it is the local folder to which the files are copied. ( Page 35, Section 8.3)
  - When the local folder is "C:\CCPUSIM"
    - "C:\CCPUSIM\CWSIMSA\vxsimnetd"

# APPENDIX

## Appendix 1 VxWorks Component List

This section explains components whose operations run differently on CW-Sim and CW-Sim Standalone among VxWorks components implemented on C Controller module.

### Remark

For all VxWorks components implemented on C Controller module, refer to the following manual.  
 C Controller Module User's Manual (Q24DHCCPU-V)

## Appendix 1.1 VxWorks 6.8 component list (Q24DHCCPU-V)

Difference	Description	Name
Addition	Write-protect vector table	INCLUDE_PROTECT_VEC_TABLE
	WDB network connection	INCLUDE_WDB_COMM_NETWORK
Deletion	Built-in symbol table	INCLUDE_STANDALONE_SYM_TBL
	PCI Bus Show Routines	INCLUDE_PCI_BUS_SHOW
	PCI Bus legacy Auto Configuration Routines	INCLUDE_PCI_OLD_CONFIG_ROUTINES
	Peripheral Component Interconnect Bus	INCLUDE_PCI_BUS
	Processor Local Bus	INCLUDE_PLB_BUS
	Intel PRO/1000 VxBus Enhanced Network Driver	INCLUDE_GEI825XX_VXB_END
	Generic PHY driver	INCLUDE_GENERICPHY
	Intel ICH SATA Controller	INCLUDE_DRV_STORAGE_INTEL_ICH
	Intel ICH SATA Controller Show Routines	INCLUDE_DRV_STORAGE_INTEL_ICH_SHOW
	MII bus controller module	INCLUDE_MII_BUS
	Pentium PCI host controller	INCLUDE_PENTIUM_PCI
	Sio Channel Utilities	INCLUDE_SIO_UTILS
	vxBus Aux Clk Support	INCLUDE_VXB_AUX_CLK
	vxBus Sys Clk Support	INCLUDE_VXB_SYS_CLK
	vxBus Timer Support	INCLUDE_TIMER_SYS
	vxBus Timestamp Support	INCLUDE_VXB_TIMESTAMP
	EHCI Init	INCLUDE_EHCI_INIT
	EHCI Start	INCLUDE_EHCI_BUS
	USB Host Stack Init	INCLUDE_USB_INIT
	EHCI	INCLUDE_EHCI
	USB Host Stack	INCLUDE_USB
	Thermal Monitor and Geyserville III support	INCLUDE_THERM_MONITOR
	General BSP macros	INCLUDE_BSP_MACROS
	32-bit physical address space	INCLUDE_MMU_P6_32BIT
	USB GEN2 Helper Init	INCLUDE_USB_GEN2_HELPER
	USB GEN2 Mass Storage Init	INCLUDE_USB_GEN2_STORAGE_INIT
	USB GEN2 Mass Storage	INCLUDE_USB_GEN2_STORAGE



## Appendix 1.2 VxWorks 6.4 component list (Q12DCCPU-V)

Difference	Description	Name
Addition	Direct access to host filesystem	INCLUDE_PASSFS
	VxSim virtual disk to emulate a VxWorks disk driver	INCLUDE_VIRTUAL_DISK

A

# Appendix 2 QBF\_Simulator Bus Interface Functions (Stub)

This section explains the stub provided in the sample program.

This function performs the simulation by using the variable in the sample program (gpsDevArea), instead of accessing to actual input signal (X) and output signal (Y).

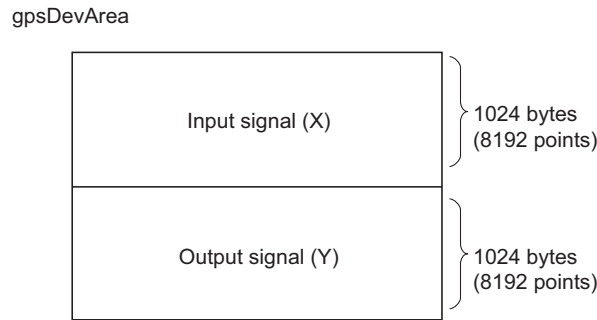

Function name	Description	Reference
QBF_Open	Simulates open bus.	Page 88, (1) in this section
QBF_Close	Simulates closed bus.	Page 88, (2) in this section
QBF_X_In_BitEx	Simulates readout of input signal (X) by bits (1 point).	Page 89, (3) in this section
QBF_X_In_WordEx	Simulates readout of input signal (X) by words (16 points).	Page 89, (4) in this section
QBF_Y_Out_BitEx	Simulates output of output signal (Y) by bits (1 point).	Page 89, (5) in this section
QBF_Y_Out_WordEx	Simulates output of output signal (Y) by words (16 points).	Page 90, (6) in this section
QBF_Y_In_BitEx	Simulates readout of output signal (Y) by bits (1 point).	Page 90, (7) in this section
QBF_Y_In_WordEx	Simulates readout of output signal (Y) by words (16 points).	Page 90, (8) in this section

## (1) QBF\_Open

Simulates open bus. (No processing)

- Argument:

Argument name	Description	IN/OUT
unit	Dummy	IN
path	Dummy	OUT

- Return value: 0

## (2) QBF\_Close

Simulates closed bus. (No processing)

- Argument:

Argument name	Description	IN/OUT
path	Dummy	IN

- Return value: 0

**(3) QBF\_X\_In\_BitEx**

Reads the input signal (X) from the memory (gpsDevArea) by bits (1 point).

- Argument:

Argument name	Description	IN/OUT
path	Dummy	IN
sFlg	Dummy	IN
usXno	Input number (X)	IN
pusData	Read data (0: OFF, 1: ON)	OUT

- Return value:  
Normal end 0  
Abnormal end -203 (input number/output number error)

**(4) QBF\_X\_In\_WordEx**

Reads the input signal (X) from the memory (gpsDevArea) by words (16 points).

- Argument:

Argument name	Description	IN/OUT
path	Dummy	IN
sFlg	Dummy	IN
usXno	Start input number (X)	IN
usSize	Number of read words	IN
pusDataBuf	Read data	OUT
usBufSize	Size of data storage area (pusDataBuf) (by words)	IN

- Return value:  
Normal end 0  
Abnormal end -203 (input number/output number error)  
Abnormal end -204 (I/O access size error)  
Abnormal end -210 (read area size error)

**(5) QBF\_Y\_Out\_BitEx**

Writes the output signal (Y) into the memory (gpsDevArea) by bits (1 point).

- Argument:

Argument name	Description	IN/OUT
path	Dummy	IN
sFlg	Dummy	IN
usYno	Output number (Y)	IN
usData	Write data (0: OFF, 1: ON)	IN

- Return value:  
Normal end 0  
Abnormal end -203 (input number/output number error)

## (6) QBF\_Y\_Out\_WordEx

Writes the output signal (Y) into the memory (gpsDevArea) by words (16 points).

- Argument:

Argument name	Description	IN/OUT
path	Dummy	IN
sFlg	Dummy	IN
usYno	First output number (Y)	IN
usSize	Number of written words	IN
pusDataBuf	Written data	IN
usBufSize	Dummy (0 fixed)	IN

- Return value:  
Normal end 0  
Abnormal end -203 (input number/output number error)  
Abnormal end -204 (input access size error)

## (7) QBF\_Y\_In\_BitEx

Reads the output signal (Y) from the memory (gpsDevArea) by bits (1 point).

- Argument:

Argument name	Description	IN/OUT
path	Dummy	IN
sFlg	Dummy	IN
usYno	Output number (Y)	IN
pusData	Read data (0: OFF, 1: ON)	OUT

- Return value:  
Normal end 0  
Abnormal end -203 (input number/output number error)

## (8) QBF\_Y\_In\_WordEx

Reads the output signal (Y) from the memory (gpsDevArea) by words (16 points).

- Argument:

Argument name	Description	IN/OUT
path	Dummy	IN
sFlg	Dummy	IN
usYno	Start output number (Y)	IN
usSize	Number of read words	IN
pusDataBuf	Read data	OUT
usBufSize	Size of data storage area pusDataBuf (by words)	IN

- Return value:  
Normal end 0  
Abnormal end -203 (input number/output number error)  
Abnormal end -204 (I/O access size error)  
Abnormal end -210 (read area size error)

## Appendix 3 Support

### Appendix 3.1 Technical support assistance service regarding C Controller module

For technical support assistance service regarding C Controller module, refer to the table below.

If you are not sure which type the inquiry belongs to, please contact us. Please note that inquiries other than MELSEC-related inquiries may not be able to be answered.

Type	Inquiry	Where to contact
MELSEC-related	<ul style="list-style-type: none"> <li>• Functions and specifications of C Controller module</li> <li>• Specifications and usage of the dedicated function library provided by Mitsubishi Electric Corporation</li> <li>• C controller setting and monitoring tool, and functions and specifications of CW Workbench, CW-Sim and CW-Sim Standalone.</li> <li>• Functions and specifications of the Mitsubishi products to be used with C Controller module (such as units and MELSOFT)</li> </ul>	 Information and services For further information and services, please consult your local Mitsubishi representative
Operating system-related	<ul style="list-style-type: none"> <li>• Functions and specifications of VxWorks, API functions provided by VxWorks, and general inquiries regarding programming related to VxWorks</li> <li>• Functions and specifications of Wind River Workbench and Tornado</li> </ul>	Wind River Systems, Inc. URL: <a href="http://www.windriver.com">http://www.windriver.com</a>
Plug-in software-related	<ul style="list-style-type: none"> <li>• Inquiries regarding the plug-in software to be used with CW Workbench or Wind River Workbench</li> </ul>	Plug-in software manufacturer

A

# INDEX

<b>A</b>		<b>M</b>	
Applying Permanent License . . . . .	23	MELSEC data link function . . . . .	9
<b>B</b>		<b>O</b>	
Building project using sample program . . . . .	64	Obtaining Permanent License . . . . .	22
Bus interface function . . . . .	9	Opening a sample program . . . . .	63
<b>C</b>		OPERATING ENVIRONMENT . . . . .	14
C Controller module . . . . .	9	<b>Q</b>	
C Controller module-dedicated function . . . . .	9	QbfFunc.h . . . . .	63
Communication Paths Available for CW-Sim/CW-Sim Standalone . . . . .	13	QBF_Simulator Bus Interface Functions (Stub) . . . . .	88
Contents of CW-Sim CD-ROM . . . . .	16	<b>R</b>	
Contents of CW-Sim Standalone CD-ROM . . . . .	17	Re-applying Permanent License . . . . .	25
Creating new project . . . . .	54	<b>S</b>	
Creating project using sample program . . . . .	61	Sample program configuration . . . . .	61
Creating Simulator . . . . .	71	Sample program operations . . . . .	62
CW Workbench . . . . .	9	Sample program preparation . . . . .	62
CW-Sim . . . . .	9	Setting network driver . . . . .	41,46,50
CW-Sim product with additional license . . . . .	16	Setting Routing and Remote Access service . . . . .	40,46,50
CW-Sim product with license . . . . .	16	Setting TCP/IP . . . . .	45,49,53
CW-Sim simulation environment . . . . .	12	Simulator Settings . . . . .	73
CW-Sim Standalone . . . . .	9,16	Simulator Startup . . . . .	66,77
CW-Sim Standalone simulation environment . . . . .	12	SPECIFICATIONS . . . . .	15
<b>D</b>		STARTUP.CMD . . . . .	73,77
Debugging Program . . . . .	69	<b>T</b>	
Dedicated function library . . . . .	9	TROUBLESHOOTING . . . . .	79
Deleting Permanent License . . . . .	24	<b>U</b>	
Differences from C Controller Module . . . . .	15	Uninstallation of CW-Sim . . . . .	35
<b>E</b>		Uninstallation of CW-Sim Standalone . . . . .	36
Execution of Sample Program . . . . .	74	<b>V</b>	
<b>F</b>		VxSim . . . . .	9
firewall exception list . . . . .	85	VxSim Network Daemon . . . . .	85
<b>H</b>		vxsimnetd.conf . . . . .	65,76
How to Apply Patch . . . . .	38	vxsimnetd.exe . . . . .	85
How to build new project . . . . .	64	VxWorks 6.4 component list . . . . .	87
How to Obtain Patch . . . . .	38	VxWorks 6.8 component list . . . . .	86
<b>I</b>		VxWorks NETWORK DAEMON SETTINGS . . . . .	40
Installation at X YYYY . . . . .	38,81	VxWorks Network Daemon Startup . . . . .	65,71,76
Installation of CW-Sim . . . . .	27	<b>W</b>	
Installation of CW-Sim Standalone . . . . .	35	Wind River Systems, Inc. . . . .	91
Installation using a permanent license . . . . .	32	Wind River Workbench . . . . .	9
Installation using a temporary license . . . . .	31	WindRiver WRTAP . . . . .	43,45,48,49,52,53

wrtap.inf . . . . .43,48,52







# Memo

---

Microsoft, Windows, and Windows Vista are registered trademarks of Microsoft Corporation in the United States and other countries.

Core2Duo is a trademark of Intel Corporation in the United States and other countries.

Ethernet is a trademark of Xerox Corporation.

VxWorks is a registered trademark of Wind River Systems, Inc.

Adobe Reader is registered trademarks of Adobe Systems Incorporated in the United States and/or other countries.



# CW-Sim (VxWorks Simulator for CW Workbench) Operating Manual

MODEL	SW1DNC-CWSIM-O-E
MODEL CODE	13JU77
SH(NA)-081159ENG-A(1303)KWIX	



HEAD OFFICE : TOKYO BUILDING, 2-7-3 MARUNOUCHI, CHIYODA-KU, TOKYO 100-8310, JAPAN  
NAGOYA WORKS : 1-14, YADA-MINAMI 5-CHOME, HIGASHI-KU, NAGOYA, JAPAN

When exported from Japan, this manual does not require application to the Ministry of Economy, Trade and Industry for service transaction permission.

Specifications subject to change without notice.